

KENDRIYA VIDYALAYA SANGATHAN, RAIPUR REGION (2022-23)
CLASS XII –MATHEMATICS

CHAPTER 1 : RELATIONS AND FUNCTIONS

Ordered Pair:

A pair of elements listed in a specific order separated by comma and enclosing the pair in parenthesis is called an ordered pair.

For example, (a, b) is an ordered pair with a as the first element and b as the second element.

Cartesian Product or Cross Product of sets A and B:

The set of ordered pairs (a, b) such that $a \in A, b \in B$ is called the cartesian product of A to B. The set of ordered pairs (b, a) such that $a \in A, b \in B$ is called the cartesian product of B to A.

It is written as:

$$A \times B = \{(a, b): a \in A, b \in B\}$$

$$A \times B = \{(b, a): a \in A, b \in B\}$$

Number of elements in A x B:

If $n(A) = p$ and $n(B) = q$ then $n(A \times B) = pq$

Relation from Set A to set B:

Let A and B be two non-empty sets, then a relation R from set A to set B is a subset of cartesian product $A \times B$.

Relation on a Set:

Let A be a non-empty set. Then, a relation from A to A is called a relation on set A.

Domain, Range and Codomain of Relation:

Let R be a relation from set A to set B, then the set of all the first elements of the ordered pairs in R is called the domain and the set of all the second elements of the ordered pairs in R is called the range of R, i.e., Domain of $R = \{a: (a, b) \in R\}$ and Range of $R = \{b: (a, b) \in R\}$. The set B is called the codomain of relation R.

Empty Relation:

A relation from set A to set B is said to be empty if no element of A is related to any element of B, and is denoted by \emptyset . An empty relation is a subset of $A \times B$.

Universal Relation:

A relation from set A to set B is said to be universal if each element of A is related to every element of B. Universal relation $U = A \times B$.

NOTE: Empty relation and Universal relation are said to be trivial relations.

Identity Relation:

A relation R on the set A is an identity relation if and only if $R = \{(a, a) \text{ for each } a \in A\}$.

Types of Relations:

A relation on a non-empty set A is said to be

- (i) Reflexive, if $(a, a) \in R$ for all $a \in A$.
- (ii) Symmetric, if $(a, b) \in R$ implies $(b, a) \in R$, for all $a, b \in A$.
- (iii) Transitive, if $(a, b) \in R$ and $(b, c) \in R$ implies $(a, c) \in R$, for all $a, b, c \in A$.

Equivalence Relation:

A relation R on a set A is said to be an equivalence relation if R is reflexive, symmetric and transitive.

Equivalence Classes:

Let R be an equivalence relation on a set A . The set of all those elements of A , which are related to a , where $a \in A$, is said equivalence class determined by a and is denoted by $[a]$.

Given an arbitrary relation R on an arbitrary set A , R divides A into mutually disjoint subsets A_i , called partitions or subdivisions of A , satisfying the conditions:

- (i) All elements of A_i are related to each other, for each i .
- (ii) No element of A_j is related to any element of A_i , for all $i \neq j$.
- (iii) $A_i \cap A_j = \emptyset$, for all i, j .

Function (Mapping):

For any two non-empty sets A and B , a function f from A to B is a rule or mapping which associates each element of set A to a unique element in set B . It is denoted by $f : A \rightarrow B$.

Domain, Codomain and Range of a Function:

Let $f : A \rightarrow B$ then elements of set A are called domain of f and the elements of set B are called codomain of f . The set of all the images obtained in set B corresponding to each element belongs to A under f is called range.

Types of Functions:

One-one (or injective function): A function $f : A \rightarrow B$ is called a one-one or injective function, if distinct elements of A have distinct images in B .

i.e., for every $x_1, x_2 \in A$, $f(x_1) = f(x_2)$ implies $x_1 = x_2$

Many-one function:

A function $f : A \rightarrow B$ is called a many-one function, if there exist at least two distinct elements in A , whose images are same in B .

Onto (or surjective function):

A function $f : A \rightarrow B$ is said to be onto or surjective function, if every element of B is the image of some elements of A under f .

i.e., for every $y \in B$ there exists an element $x \in A$ such that $f(x) = y$

Into function:

A function $f : A \rightarrow B$ is an into function, if there exists an element in B which have no pre-image in A .

One-one and onto (or bijective function):

A function $f : A \rightarrow B$ is said to be one-one and onto (or bijective function), if f is both one-one and onto.

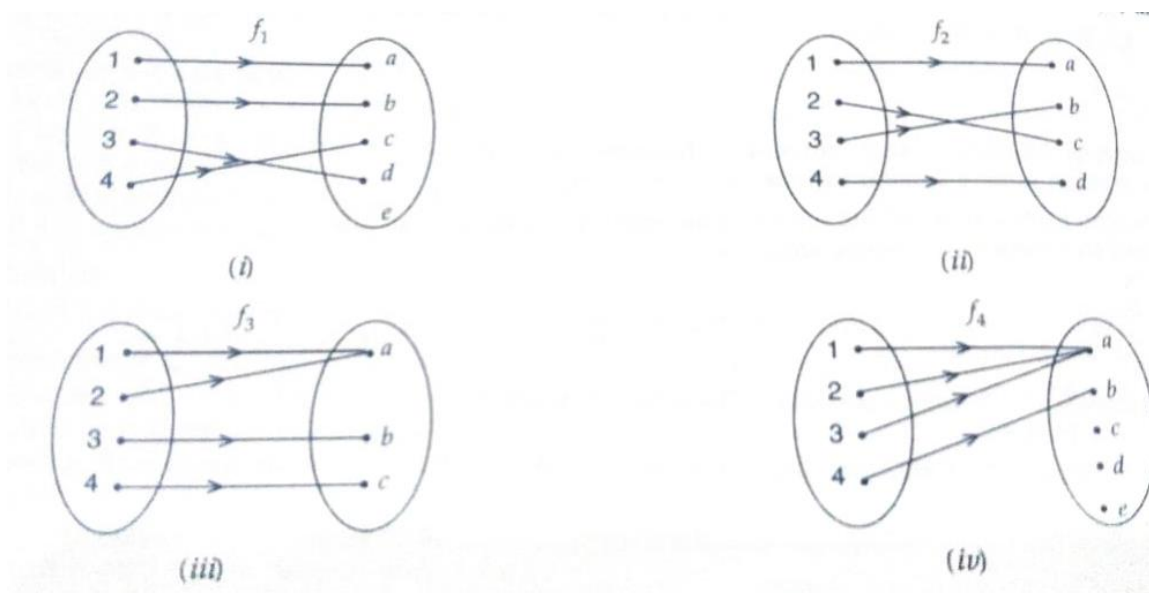

In the figures, the functions f_1 and f_2 are one-one and the functions f_3 and f_4 are many-one. The functions f_2 and f_3 are onto and the functions f_1 and f_4 are into.

Number of Relations from set A to set B:

If $n(A) = p$ and $n(B) = q$ then

Number of Relations from A to B = 2^{pq}

Number of Reflexive Relations on a Set:

The number of reflexive relations on a set with the 'n' number of elements is given by $N = 2^{n(n-1)}$

Number of Symmetric Relations on a Set:

Number of Symmetric relations for a set having 'n' number of elements is given as $N = 2^{n(n+1)/2}$

Number of Functions:

If a set A has m elements and set B has n elements, then

The total number of functions from A to B = n^m

Number of Surjective Functions (Onto Functions):

If a set A has m elements and set B has n elements, then

The number of onto functions from A to B = $n^m - {}^nC_1(n-1)^m + {}^nC_2(n-2)^m - {}^nC_3(n-3)^m + \dots - {}^nC_{n-1}$

Number of Injective Functions (One to One Functions):

If set A has m elements and set B has n elements, $n \geq m$, then the number of injective functions or one to one function is given by $n!/(n - m)!$.

Number of Bijective functions:

If there is bijection between two sets A and B, then both sets will have the same number of elements. If $n(A) = n(B) = m$, then number of bijective functions = $m!$.

MULTIPLE CHOICE QUESTIONS

- If $A = \{1, 2, 3\}$ and let $R = \{(1, 1), (2, 2), (3, 3), (1, 2), (2, 1), (2, 3), (3, 2)\}$, then R is:
 - Reflexive, symmetric but not transitive
 - symmetric, transitive but not reflexive
 - Reflexive and transitive but not symmetric
 - an equivalence relation
- Let R be a relation defined on Z by $a R b \Leftrightarrow a \geq b$, then R is:
 - symmetric, transitive but not reflexive
 - Reflexive, symmetric but not transitive
 - Reflexive and transitive but not symmetric
 - an equivalence relation
- Let R be a relation defined on Z as follows: $(a, b) \in R \Leftrightarrow a^2 + b^2 = 25$, then domain of R is:
 - $\{3, 4, 5\}$
 - $\{0, 3, 4, 5\}$
 - $\{0, \pm 3, \pm 4, \pm 5\}$
 - none of these
- The relation R defined on the set $A = \{1, 2, 3, 4, 5\}$ by $R = \{(a, b) : |a^2 - b^2| < 16\}$ is given by:
 - $\{(1, 1), (2, 1), (3, 1), (4, 1), (2, 3)\}$
 - $\{(2, 2), (3, 2), (4, 2), (2, 4)\}$
 - $\{(3, 3), (4, 3), (5, 4), (3, 4)\}$
 - none of these
- Let R be a relation defined on Z as $R = \{(x, y) : |x - y| \leq 1\}$ Then R is:
 - Reflexive and transitive
 - Reflexive and symmetric
 - Symmetric and transitive
 - an equivalence relation
- Let $A = \{1, 2, 3\}$, $B = \{1, 4, 6, 9\}$ and R is a relation from A to B define by 'x is greater than y'. Then range of R is given by:

- (a) {1,4,6,9} (b) {4,6,9} (c) {1} (d) none of these

7. A relation R is defined from {2,3,4,5} to {3,6,7,10} by $x R y \Leftrightarrow x$ is relatively prime to y . Then the domain of R is given by:

- (a) {2,3,5} (b) {3,5} (c) {2,3,4} (d) {2,3,4,5}

8. Let the function $f: \mathbb{R} - \{-b\} \rightarrow \mathbb{R} - \{-1\}$ be defined by $f(x) = \frac{x+a}{x+b}$; $a \neq b$, then:

- (a) f is one-one but not onto (b) f is onto but not one-one
(c) f is both one-one and onto (d) none of these

9. The function $f: [0, \infty) \rightarrow \mathbb{R}$ given by $f(x) = \frac{x}{x+1}$ is:

- (a) f is both one-one and onto (b) f is one-one but not onto
(c) f is onto but not one-one (d) neither one-one nor onto

10. Which of the following functions from \mathbb{Z} to itself is bijection?

- (a) $f(x) = x^3$ (b) $f(x) = x + 2$ (c) $f(x) = 2x + 1$ (d) $f(x) = x^2 + x$

11. If the function $f: [2, \infty) \rightarrow B$, defined by $f(x) = x^2 - 4x + 5$ is a bijection, then B is:

- (a) \mathbb{R} (b) $[1, \infty)$ (c) $[4, \infty)$ (d) $[5, \infty)$

ASSERTION-REASON TYPE QUESTIONS

Each of the following questions contains two statements: Assertion (A) and Reason (R). Each of the questions has four alternative choices, only one of which is the correct statement.

- (a) Both 'A' and 'R' are true and 'R' is the correct explanation of 'A'.
(b) Both 'A' and 'R' are true but 'R' is not the correct explanation of 'A'.
(c) 'A' is true but 'R' is false.
(d) 'A' is false but 'R' is true.

12. **Assertion (A)**: $f(x) = |x - 2| + |x - 3| + |x - 5|$ is an odd function for all values of x between 3 and 5.

Reason (R): $f(-x) = -f(x)$ for odd function.

13. Let $f(x) = \frac{1}{3} * \left(\frac{|\sin x|}{\cos x} + \frac{\sin x}{|\cos x|} \right)$

Assertion (A): The period of $f(x)$ is 2π .

Reason (R): The period of $\sin x$ and $\cos x$ is 2π .

14. **Assertion (A)**: Every even function $y = f(x)$ is not one-one for all in $x \in D_f$.

Reason (R): Even function is symmetrical about $y -$ axis.

Case Study

15. Sherlin and Danju are playing Ludo at home during Covid-19. While rolling the dice, Sherlin's sister Raji observed and noted the possible outcomes of the throw every time belongs to set {1, 2, 3, 4, 5, 6}. Let A be the set of players while B be the set of all possible outcomes.

$$A = \{S, D\}, B = \{1, 2, 3, 4, 5, 6\}$$



Based on the above information, answer the following:

- (i) Raji wants to know the number of functions from A to B. How many number of functions are possible?
 - (ii) Raji wants to know the number of relations possible from A to B. How many number of relations are possible?
 - (iii) Let $R: B \rightarrow B$ be defined by $R = \{(1, 1), (1, 2), (2, 2), (3, 3), (4, 4), (5, 5), (6, 6)\}$, then which type of the relation is R?
16. Raji visited the Exhibition along with her family. The Exhibition had a huge swing, which attracted many children. Raji found that the swing traced the path of a parabola as given by $y = x^2$.



Based on the above information, answer the following:

- (i) Let $f: \mathbb{N} \rightarrow \mathbb{N}$ be defined by $f(x) = x^2$. Then which type of the function is f ?
- (ii) Let $f: \mathbb{N} \rightarrow \mathbb{R}$ be defined by $f(x) = x^2$. Range of the function among the following is:
- (iii) The function $f: \mathbb{Z} \rightarrow \mathbb{Z}$ defined by $f(x) = x^2$. Then which type of the function is f ?

SHORT ANSWER QUESTIONS (2 marks each)

- 17. Let $f: \mathbb{R} \rightarrow \mathbb{R}$ be defined as $f(x) = |x|$. Check whether f is one-one and onto?
- 18. Let $f: \mathbb{R} \rightarrow \mathbb{R}$ be defined as $f(x) = [x]$. Check whether f is one-one and onto?
- 19. Show that the relation R in the set $\{1, 2, 3\}$ given by $R = \{(1, 2), (2, 1)\}$ is symmetric but neither reflexive nor transitive.
- 20. Find the maximum number of equivalence relations on the set $A = \{1, 2, 3\}$.

SHORT ANSWER QUESTIONS (3 marks each)

21. Show that the relation R in the set R of real numbers, defined as $R = \{(a, b) : a \leq b^2\}$ is neither reflexive nor symmetric nor transitive
22. Consider $f : R - \left\{-\frac{4}{3}\right\} \rightarrow R - \left\{\frac{4}{3}\right\}$ given by $f(x) = \frac{4x+3}{3x+4}$. Show that f is bijective.
23. Show that the relation R defined in the set A of all polygons as $R = \{(P_1, P_2) : P_1 \text{ and } P_2 \text{ have same number of sides}\}$, is an equivalence relation.
24. Let $f : N \rightarrow N$ be defined by
- $$f(n) = \begin{cases} n + 1, & \text{if } n \text{ is odd} \\ n - 1, & \text{if } n \text{ is even} \end{cases}, \quad \text{show that f is bijective.}$$

LONG ANSWER QUESTIONS (5 marks each)

25. Let $A = \{1, 2, 3, \dots, 9\}$ and R be the relation in A defined by $(a, b) R (c, d)$ iff $a + d = b + c$ for all $a, b, c, d \in A$. Prove that R is an equivalence relation. Also obtain the equivalence class $[(2, 5)]$.
26. Show that the relation R in the set $A = \{1, 2, 3, 4, 5\}$ given by $R = \{(a, b) : |a - b| \text{ is divisible by } 2\}$ is an equivalence relation. Show that all the elements of $\{1, 3, 5\}$ are related to each other and all the elements of $\{2, 4\}$ are related to each other, but no element of $\{1, 3, 5\}$ is related to any element of $\{2, 4\}$.
27. Let $A = \{x \in Z : 0 \leq x \leq 12\}$. Show that $R = \{(a, b) : a, b \in A, |a - b| \text{ is divisible by } 4\}$ is an equivalence relation. Find the set of all elements related to 1. Also write the equivalence class $[2]$.
28. Let R be a relation on the set $A = N \times N$, where N is the set of natural numbers, defined by $(x, y) R (u, v)$ if and only if $xv = yu$. Show that R is an equivalence relation.
29. Show that the relation R in the set $N \times N$, defined by $(a, b) R (c, d)$ iff $a^2 + d^2 = b^2 + c^2 \forall a, b, c, d \in N$, is an equivalence relation.
30. Let N denote the set of all natural numbers and R be the relation on $N \times N$ defined by $(a, b) R (c, d)$ iff $ad(b + c) = bc(a + d)$. Show that R is an equivalence relation.
31. Show that the function $f : R \rightarrow \{x \in R : -1 < x < 1\}$ defined by $f(x) = \frac{x}{1+|x|}$, $x \in R$ is one one and onto function.

ANSWERS

1. a 2. c 3. c 4. d 5. b 6. c 7. d 8. c 9. b 10. b 11. b

12. (a) 13. (b) 14. (d) 15. (i) 6^2 (ii) 2^{12} (iii) reflexive and transitive

16. (i) injective (ii) $\{1, 4, 9, 16, \dots\}$ (iii) neither injective nor surjective

20. There is a maximum of 5 equivalence relations on the set $A = \{1, 2, 3\}$.

They are

$$R_1 = \{(1, 1), (2, 2), (3, 3)\}$$

$$R_2 = \{(1, 1), (2, 2), (3, 3), (1, 2), (2, 1)\}$$

$$R_3 = \{(1, 1), (2, 2), (3, 3), (1, 3), (3, 1)\}$$

$$R_4 = \{(1, 1), (2, 2), (3, 3), (2, 3), (3, 2)\}$$

$$R_5 = \{(1, 1), (2, 2), (3, 3), (1, 2), (2, 1), (1, 3), (3, 1), (2, 3), (3, 2)\}$$

25. $\{(1, 4), (2, 5), (3, 6), (4, 7), (5, 8), (6, 9)\}$

27. $\{1, 3, 5\}$; $[2] = \{2, 6, 10\}$

KENDRIYA VIDYALAYA SANGATHAN, RAIPUR REGION (2022-23)
CLASS XII –MATHEMATICS

CHAPTER 2 : INVERSE TRIGONOMETRIC FUNCTIONS

CBSE SYLLABUS: - Definition, range, domain, principal value branch. Graphs of inverse trigonometric function.

Gist of topic: The domain of sine function is the set of all **real** numbers and range is the closed interval **$[-1, 1]$** .

If we restrict its domain to $\left[\frac{-\pi}{2}, \frac{\pi}{2} \right]$, then it becomes one-one and onto with range $[-1, 1]$.

Actually, sine function restricted to any of the intervals $\left[\frac{-3\pi}{2}, \frac{-\pi}{2} \right], \left[\frac{-\pi}{2}, \frac{\pi}{2} \right], \text{or} \left[\frac{\pi}{2}, \frac{3\pi}{2} \right], \dots$ etc., is one-one and its range is $[-1, 1]$.

therefore, define the inverse of sine function in each of these intervals.

We denote the inverse of sine function by \sin^{-1} (arc sine function).

Thus, \sin^{-1} is a function whose domain is $[-1, 1]$ and range could be any of the intervals

$\left[\frac{-3\pi}{2}, \frac{-\pi}{2} \right], \left[\frac{-\pi}{2}, \frac{\pi}{2} \right], \text{or} \left[\frac{\pi}{2}, \frac{3\pi}{2} \right], \dots$, and so on. Corresponding to each such interval,

we get a branch of the function \sin^{-1} . The branch with range, $\left[\frac{-\pi}{2}, \frac{\pi}{2} \right]$ is called the principal value

branch, whereas other intervals as range give different branches of \sin^{-1} . When we refer to the

function \sin^{-1} , we take it as the function whose domain is $[-1, 1]$ and range is $\left[\frac{-\pi}{2}, \frac{\pi}{2} \right]$. We write

$$\sin^{-1} : [-1, 1] \rightarrow \left[\frac{-\pi}{2}, \frac{\pi}{2} \right]$$

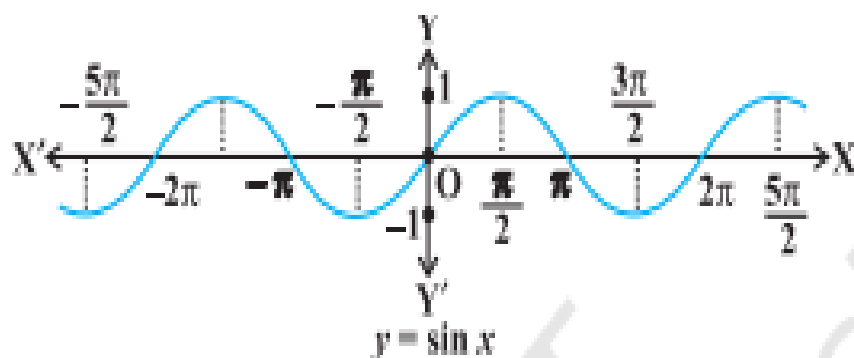
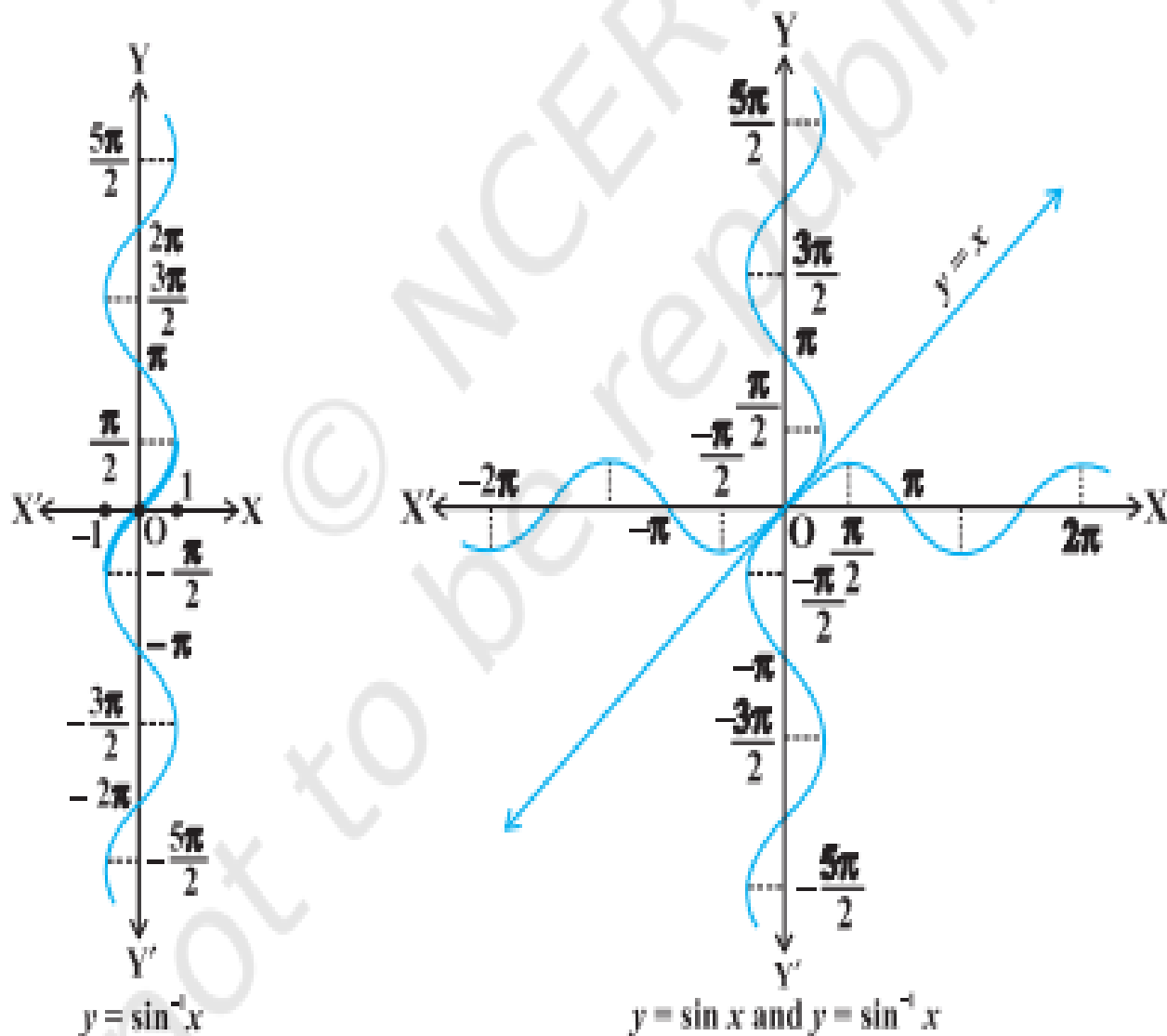

Fig 2.1 (i)



The cosine function is a function whose domain is the set of all **real numbers** and range is the set $[-1, 1]$.

If we restrict the domain of cosine function to $[0, \pi]$, then it becomes one-one and onto with range $[-1, 1]$. Actually, cosine function restricted to any of the intervals $[-\pi, 0]$, $[0, \pi]$, $[\pi, 2\pi]$ etc., is bijective with range as $[-1, 1]$.

We can, therefore, define the inverse of cosine function in each of these intervals. We denote the inverse of the cosine function by \cos^{-1} (arc cosine function).

Thus, \cos^{-1} is a function whose domain is $[-1, 1]$ and range could be any of the intervals $[-\pi, 0]$, $[0, \pi]$, $[\pi, 2\pi]$ etc. Corresponding to each such interval,

we get a branch of the function \cos^{-1} . The branch with range $[0, \pi]$ is called the principal value branch of the function \cos^{-1} .

We write $\cos^{-1} : [-1, 1] \rightarrow [0, \pi]$

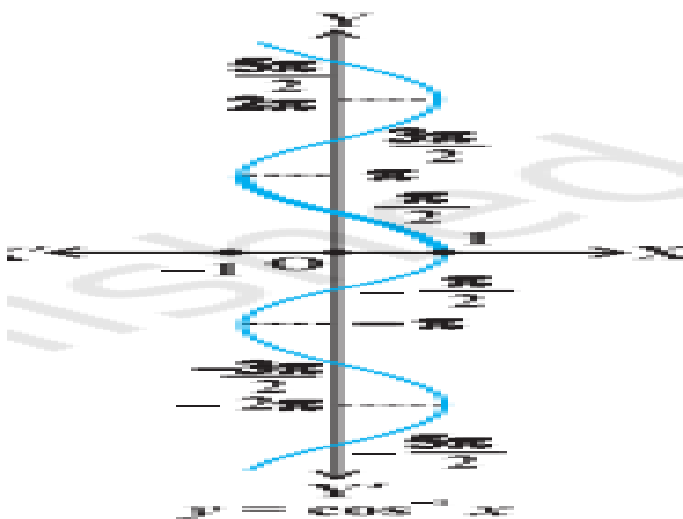
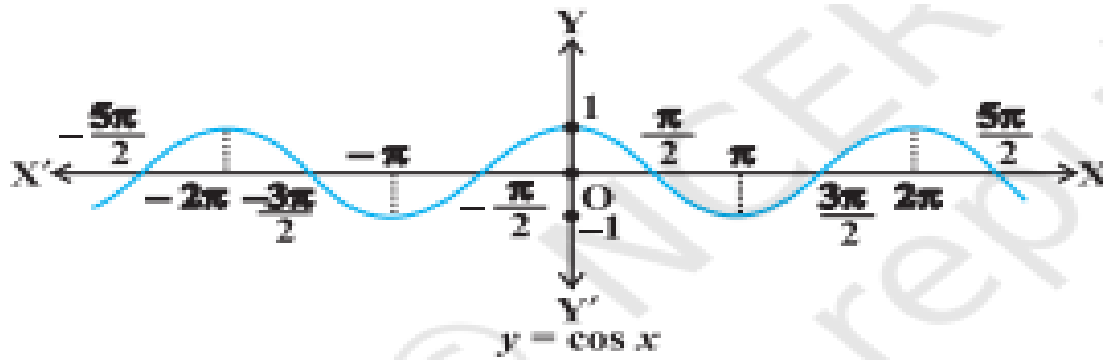

Domain and Range of inverse-trigonometric function

Functions	Domain	Range (Principal value branches)
$y = \sin^{-1}x$	$[-1,1]$	$\left[-\frac{\pi}{2}, \frac{\pi}{2}\right]$
$y = \cos^{-1}x$	$[-1,1]$	$[0, \pi]$
$y = \operatorname{cosec}^{-1}x$	$\mathbf{R} - (-1,1)$	$\left[-\frac{\pi}{2}, \frac{\pi}{2}\right] - \{0\}$
$y = \sec^{-1}x$	$\mathbf{R} - (-1,1)$	$[0, \pi] - \left\{\frac{\pi}{2}\right\}$
$y = \tan^{-1}x$	\mathbf{R}	$\left(-\frac{\pi}{2}, \frac{\pi}{2}\right)$
$y = \cot^{-1}x$	\mathbf{R}	$(0, \pi)$

Competency based question: Type 1-MCQ

Q1 One branch of \cos^{-1} other than the principal value branch corresponds to

- (A) $\left[-\frac{\pi}{2}, \frac{\pi}{2}\right]$ (B) $\left[-\frac{\pi}{2}, \frac{\pi}{2}\right]$ (C) $(0, \pi)$ (D) $[2\pi, 3\pi]$

Q2 The domain of $y = \cos^{-1}(x^2 - 4)$ is

- (A) $[3, 5]$ (B) $[0, \pi]$ (C) $[-\sqrt{5}, -\sqrt{3}] \cap [-\sqrt{5}, \sqrt{3}]$ (D) $[-\sqrt{5}, -\sqrt{3}] \cup [\sqrt{3}, \sqrt{5}]$

Q3 If $\sin^{-1}x + \sin^{-1}y = \pi/2$, then value of $\cos^{-1}x + \cos^{-1}y$ is

- (A) $\frac{\pi}{2}$ (B) π (C) 0 (D) $\frac{3\pi}{2}$

Q4 The domain of the function $\cos^{-1}(2x - 1)$ is

- (A) $[0, 1]$ (B) $[-1, 1]$ (C) $[-2, 1]$ (D) $[0, \pi]$

Q5 the value of $\sin^{-1}\left[\cos\frac{33\pi}{5}\right]$ is

- (A) $\frac{3\pi}{5}$ (B) $-\frac{7\pi}{5}$ (C) $\frac{\pi}{10}$ (D) $-\frac{\pi}{10}$

Q6 The domain of the function $y = \sin^{-1}(-x^2)$ is

- (A) $[0, 1]$ (B) $(0, 1)$ (C) $[-1, 1]$ (D) ϕ

Q7 The domain of the function defined by $f(x) = \sin^{-1}x + \cos x$ is

- (A) $[-1, 1]$ (B) $[-1, \pi + 1]$ (C) $(-\infty, \infty)$ (D) ϕ

Q8 Which of the following corresponds to the principal value branch of \sin^{-1} ?

$$(A) \left[\frac{-\pi}{2}, \frac{\pi}{2} \right] \quad (B) \left[\frac{-3\pi}{2}, \frac{-\pi}{2} \right] \quad (C) \left[\frac{-\pi}{2}, \frac{\pi}{2} \right] - \{0\} \quad (D) (0, \pi)$$

ANSWERS : (1) $[2\pi, 3\pi]$ (2) $[-\sqrt{5}, -\sqrt{3}] \cup [\sqrt{3}, \sqrt{5}]$ (3) $\frac{\pi}{2}$ (4) $[0, 1]$ (5) $\frac{-\pi}{10}$ (6) $[-1, 1]$ (7) $[-1, 1]$ (8)

$$\left[\frac{-\pi}{2}, \frac{\pi}{2} \right]$$

Competency based question: Type 2-Assertion -reason based questions.

In the following questions, a statement of assertion (A) is followed by a statement of Reason (R). Choose the correct answer out of the following choices.

- (a) Both A and R are true and R is the correct explanation of A.
- (b) Both A and R are true but R is not the correct explanation of A.
- (c) A is true but R is false.
- (d) A is false but R is true.

Q1 Assertion (A): The domain of the function $\sec^{-1} 2x$ is $\left(-\infty, \frac{-1}{2}\right] \cup \left[\frac{1}{2}, \infty\right)$

$$\text{Reason (R): } \sec^{-1}(-2) = \frac{-\pi}{4}$$

Q2 Assertion(A): The domain of the function $\cos^{-1} x$ is $[-1, 1]$

$$\text{Reason (R) : } \cos^{-1}\left(\frac{-1}{2}\right) = \frac{2\pi}{3}$$

Q3 Assertion(A): The Principal value branch of $\operatorname{cosec}^{-1} x$ is $\left(\frac{-\pi}{2}, \frac{\pi}{2}\right) - \{0\}$

$$\text{Reason (R) } \operatorname{cosec}^{-1}\left(\frac{-2}{\sqrt{3}}\right) = \frac{2\pi}{3}$$

Q4 Assertion (A) The Domain of the function $\cot^{-1}(2x)$ is $(-\infty, \infty)$

$$\text{Reason (R) } \cot^{-1}(-1) = \frac{3\pi}{4}$$

Q5 Assertion (A) : The domain of the function defined by $f(x) = \sin^{-1}(\sqrt{1-x})$ is $[1, 2]$

$$\text{Reason (R) : } \sin^{-1}\left(\frac{-1}{2}\right) = \frac{\pi}{6}$$

ANSWERS: (1) c (2) b (3) d (4) a (5) c

Competency based question: Type 3 :Short answer questions

Q1 Find the value of x, $\sin\left(\sin^{-1}\left(\frac{1}{5}\right) + \cos^{-1}(x)\right) = 1$

Q2 Find the value of : $\sin\left(2 \tan^{-1}\left(\frac{2}{3}\right)\right) + \cos(\tan^{-1} \sqrt{3})$

Q3 Find the value of $\sin^{-1}\left(\sin \frac{3\pi}{5}\right)$.

Q4 Write the principal value of $\cos^{-1}\left(\cos \frac{7\pi}{6}\right)$

Q5 Evaluate: $\tan\left(2 \tan^{-1} \frac{1}{5}\right)$

Q6. Find the value of : $\cos^{-1}\left(\cos \frac{13\pi}{6}\right) + \tan^{-1}\left(\tan \frac{3\pi}{4}\right)$

Q7 Evaluate: $\sin\left[\frac{\pi}{6} - \sin^{-1}\left(-\frac{\sqrt{3}}{2}\right)\right]$

Q8 Find the value of $\sin\left(\sin^{-1} \frac{1}{2} + \cos^{-1} \frac{3}{5}\right)$

Q9. Evaluate: $\sin\left(2 \cos^{-1}\left(-\frac{3}{5}\right)\right)$

Q10. The value of $\cos^{-1}\left(-\frac{1}{2}\right) - 2 \sin^{-1}\left(\frac{1}{2}\right)$

Answer: (1). $\frac{1}{5}$ (2). $\frac{37}{26}$ (3). $\frac{2\pi}{5}$ (4). $\frac{5\pi}{6}$ (5). $\frac{5}{12}$ (6). $:-\frac{\pi}{12}$ (7). 1 (8) $\frac{3+4\sqrt{3}}{10}$ (9) $-\frac{24}{25}$ (10) $\frac{\pi}{3}$

KENDRIYA VIDYALAYA SANGATHAN RAIPUR REGION

CHAPTER 3 & 4 : MATRICES & DETERMINANTS

SCHEMATIC DIAGRAM

MATRIX: If mn elements can be arranged in the form of m row and n column in a rectangular array then this arrangement is called a matrix.

Order of a matrix: A matrix having m row and n column is called a matrix of $m \times n$ order.

Types of Matrices

(i) **Column matrix:** A matrix is said to be a column matrix if it has only one column e.g. $\begin{bmatrix} 2 \\ 1 \\ 3 \end{bmatrix}$

(ii) **Row matrix:** A matrix is said to be a row matrix if it has only one row e.g. $[1 \ 2 \ 3]$

(iii) **Square matrix:** A matrix in which the number of rows are equal to the number of columns, is said to be a square matrix. Thus an $m \times n$ matrix is said to be a square matrix if $m = n$ and is known as a square matrix of

order 'n' e.g. $\begin{bmatrix} a & b & c \\ d & e & f \\ g & h & i \end{bmatrix}$  CHAPTER2 INVERSE TRIGONOMETRIC FU

(iv) **Diagonal matrix:** A square matrix $B = [b_{ij}]_{m \times m}$ is said to be a diagonal matrix if all its non diagonal elements are zero, that is a matrix $B = [b_{ij}]_{m \times m}$ is said to be a diagonal matrix if $b_{ij} = 0$, when $i \neq j$

$$\text{e.g. } \begin{bmatrix} a & 0 & 0 \\ 0 & e & 0 \\ 0 & 0 & i \end{bmatrix}$$

(v) **Scalar matrix:** A diagonal matrix is said to be a scalar matrix if its diagonal elements are equal, that is, a square matrix $B = [b_{ij}]_{n \times n}$ is said to be a scalar matrix if $b_{ij} = 0$, when $i \neq j$ $b_{ij} = k$, when $i = j$, for some constant k .

$$\text{e.g. } \begin{bmatrix} a & 0 & 0 \\ 0 & a & 0 \\ 0 & 0 & a \end{bmatrix}$$

(vi) **Identity matrix:** A square matrix in which elements in the diagonal are all 1 and rest are all zero is called an identity matrix.

$$\text{e.g. } \begin{bmatrix} 1 & 0 & 0 \\ 0 & 1 & 0 \\ 0 & 0 & 1 \end{bmatrix}$$

(vii) **Zero matrix:** A matrix is said to be zero matrix or null matrix if all its elements are zero. For example, $[0]$,

$$\begin{bmatrix} 0 & 0 & 0 \\ 0 & 0 & 0 \\ 0 & 0 & 0 \end{bmatrix}$$

Addition and subtraction of matrices: Two matrices A and B can be added or subtracted if they are of the same order i.e. if A and B are two matrices of order $m \times n$ then $A \pm B$ is also a matrix of order $m \times n$.

Multiplication of matrices: The product of two matrices A and B can be defined if the number of rows of B is equal to the number of columns of A i.e. if A be an $m \times n$ matrix and B be an $n \times p$ matrix then the product of matrices A and B is another matrix of order $m \times p$.

Transpose of a Matrix: If $A = [a_{ij}]$ be an $m \times n$ matrix, then the matrix obtained by interchanging the rows and columns of A is called the *transpose* of A . Transpose of the matrix A is denoted by A' or A^T .

Properties of transpose of the Matrices: For any matrices A and B of suitable orders, we have

$$(i) \quad (A^T)^T = A \quad (ii) \quad (KA)^T = KA^T \quad (iii) \quad (A + B)^T = A^T + B^T \quad (iv) \quad (AB)^T = B^T A^T$$

Symmetric Matrix: A square matrix M is said to be symmetric if $A^T = A$

e.g. $\begin{bmatrix} a & b \\ b & c \end{bmatrix}, \begin{bmatrix} x & y & z \\ y & u & v \\ z & v & w \end{bmatrix}$

Note: **there will be symmetry about the principal diagonal in Symmetric Matrix.**

Skew symmetric Matrix: A square matrix M is said to be skew symmetric if $A^T = -A$

e.g. $\begin{bmatrix} 0 & e & f \\ -e & 0 & g \\ -f & -g & 0 \end{bmatrix}$

Note: **All the principal diagonal element of a skew symmetric Matrix are zero.**

Determinant: For every Square Matrix we can associate a number which is called the Determinant of the square Matrix.

Determinant of a matrix of order one

Let $A = [a]$ be the matrix of order 1, then determinant of A is defined to be equal to a .

Determinant of a matrix of order two

Let $A = \begin{bmatrix} a & b \\ x & y \end{bmatrix}$ be a Square Matrix of order 2×2 then the determinant of A is denoted by $|A|$ and defined by

$$|A| = \begin{vmatrix} a & b \\ x & y \end{vmatrix} = ay - bx$$

Determinant of a matrix of order 3×3 : Let us consider the determinant of a square matrix of order 3×3 ,

$$|A| = \begin{vmatrix} a & b & c \\ p & q & r \\ x & y & z \end{vmatrix}$$

Expansion along first row $|A| = a(qz - yr) - b(pz - xr) + c(py - qx)$

We can expand the determinant with respect to any row or any column.

Area of a Triangle: area of a triangle whose vertices are (x_1, y_1) , (x_2, y_2) and (x_3, y_3) , can be written in the form of a determinant as

$$\Delta = \frac{1}{2} \begin{vmatrix} x_1 & y_1 & 1 \\ x_2 & y_2 & 1 \\ x_3 & y_3 & 1 \end{vmatrix}$$

Remarks: (i) Since area is a positive quantity, we always take the absolute value of the determinant

(ii) If area is given, use both positive and negative values of the determinant for calculation. (iii) The area of the triangle formed by three collinear points is zero.

Minors and cofactors:

Minor of an element a_{ij} of a determinant is the determinant obtained by deleting its i th row and j th column in which element a_{ij} lies. Minor of an element a_{ij} is denoted by M_{ij} .

Cofactors: cofactors of an element a_{ij} denoted by A_{ij} and is defined by $A_{ij} = (-1)^{i+j}M_{ij}$ where M_{ij} is the minor of a_{ij} .

Adjoint of a Matrix: Let $A = \begin{bmatrix} \alpha & \beta \\ \gamma & \delta \end{bmatrix}$ be a Matrix of order 2×2

$$\text{Then adj(A)} = \begin{bmatrix} \delta & -\beta \\ -\gamma & \alpha \end{bmatrix}$$

Again let $A = \begin{bmatrix} x & y & z \\ p & q & r \\ a & b & c \end{bmatrix}$ be a Matrix of order 3×3

$$\text{Then adj(A)} = \begin{bmatrix} \begin{vmatrix} q & r \\ b & c \end{vmatrix} & -\begin{vmatrix} p & r \\ a & c \end{vmatrix} & \begin{vmatrix} p & q \\ a & b \end{vmatrix} \\ -\begin{vmatrix} y & z \\ b & c \end{vmatrix} & \begin{vmatrix} x & z \\ a & c \end{vmatrix} & -\begin{vmatrix} x & y \\ a & b \end{vmatrix} \\ \begin{vmatrix} y & z \\ p & r \end{vmatrix} & -\begin{vmatrix} x & z \\ p & r \end{vmatrix} & \begin{vmatrix} x & y \\ p & q \end{vmatrix} \end{bmatrix}^T =$$

$$\begin{bmatrix} qc - br & -(pc - ar) & pb - aq \\ -(yc - bz) & xc - az & -(bx - ay) \\ yr - qz & -(xr - pz) & xq - py \end{bmatrix}^T = \begin{bmatrix} qc - br & bz - ay & yr - qz \\ ar - pc & xc - az & pz - xr \\ pb - aq & ay - bx & xq - py \end{bmatrix}$$

Inverse of a Matrix: Inverse of a Square Matrix A is defined as $A^{-1} = \frac{\text{adj(A)}}{|A|}$

Note: If A be a given Square Matrix of order n then

- (i) $\mathbf{A(adj(A)) = adj(A)A = |A|I}$ where I is the Identity Matrix of order n .
- (ii) A square Matrix A is said to be **singular and non-singular** according as $|A| = 0$ and $|A| \neq 0$
- (iii) $\mathbf{|adj(A)| = |A|^{n-1}}$ (For a square Matrix of order 3×3 $\mathbf{|adj(A)| = |A|^2}$)

IMPORTANT SOLVED PROBLEMS

Q1. If $A = \begin{bmatrix} -2 \\ 4 \\ 5 \end{bmatrix}$, $B = [1 \ 3 \ -6]$, Verify that $(AB)' = B'A'$

Solution: - We have

$$\text{If } A = \begin{bmatrix} -2 \\ 4 \\ 5 \end{bmatrix}, \quad B = [1 \ 3 \ -6]$$

$$\text{Then } AB = \begin{bmatrix} -2 \\ 4 \\ 5 \end{bmatrix} [1 \ 3 \ -6] = \begin{bmatrix} -2 & -6 & 12 \\ 4 & 12 & -24 \\ 5 & 15 & -30 \end{bmatrix}$$

$$\text{Now } A' = [-2 \ 4 \ 5], \quad B' = \begin{bmatrix} 1 \\ 3 \\ -6 \end{bmatrix}$$

$$B'A' = \begin{bmatrix} 1 \\ 3 \\ -6 \end{bmatrix} \begin{bmatrix} -2 & 4 & 5 \end{bmatrix} = \begin{bmatrix} -2 & 4 & 5 \\ -6 & 12 & 15 \\ 12 & -24 & -30 \end{bmatrix} = (AB)'$$

Clearly $(AB)' = B'A'$

Q2. If $x \begin{bmatrix} 2 \\ 3 \end{bmatrix} + y \begin{bmatrix} -1 \\ 1 \end{bmatrix} = \begin{bmatrix} 10 \\ 5 \end{bmatrix}$ then find the value of x and y.

Sol. Given $x \begin{bmatrix} 2 \\ 3 \end{bmatrix} + y \begin{bmatrix} -1 \\ 1 \end{bmatrix} = \begin{bmatrix} 10 \\ 5 \end{bmatrix}$

$$\begin{bmatrix} 2x \\ 3x \end{bmatrix} + \begin{bmatrix} -y \\ y \end{bmatrix} = \begin{bmatrix} 10 \\ 5 \end{bmatrix} \text{ or } \begin{bmatrix} 2x - y \\ 3x + y \end{bmatrix} = \begin{bmatrix} 10 \\ 5 \end{bmatrix}$$

So $2x - y = 10$ and $3x + y = 5$; On solving we get $x = 3$ and $y = -4$

Q3. If $F(x) = \begin{bmatrix} \cos x & -\sin x & 0 \\ \sin x & \cos x & 0 \\ 0 & 0 & 1 \end{bmatrix}$ prove that $F(x) F(y) = F(x+y)$

Sol. Given $F(x) = \begin{bmatrix} \cos x & -\sin x & 0 \\ \sin x & \cos x & 0 \\ 0 & 0 & 1 \end{bmatrix}$ so $F(y) = \begin{bmatrix} \cos y & -\sin y & 0 \\ \sin y & \cos y & 0 \\ 0 & 0 & 1 \end{bmatrix}$

Hence $F(x) \cdot F(y) = \begin{bmatrix} \cos x & -\sin x & 0 \\ \sin x & \cos x & 0 \\ 0 & 0 & 1 \end{bmatrix} \begin{bmatrix} \cos y & -\sin y & 0 \\ \sin y & \cos y & 0 \\ 0 & 0 & 1 \end{bmatrix} =$

$$\begin{bmatrix} \cos x \cos y - \sin x \sin y & -\cos x \sin y - \sin x \cos y & 0 \\ \sin x \cos y + \cos x \sin y & -\sin x \sin y + \cos x \cos y & 0 \\ 0 & 0 & 1 \end{bmatrix}$$

$$= \begin{bmatrix} \cos(x+y) & -\sin(x+y) & 0 \\ \sin(x+y) & \cos(x+y) & 0 \\ 0 & 0 & 1 \end{bmatrix}$$

Hence $F(x) F(y) = F(x+y)$

Q4. Express the given Matrix as the sum of a symmetric and skew symmetric matrix

$$A = \begin{bmatrix} 6 & -2 & 2 \\ -2 & 3 & -1 \\ 2 & -1 & 3 \end{bmatrix}$$

Sol. Here $A^T = \begin{bmatrix} 6 & -2 & 2 \\ -2 & 3 & -1 \\ 2 & -1 & 3 \end{bmatrix}$

$$P = \frac{1}{2}(A + A^T) = \frac{1}{2} \begin{bmatrix} 12 & -4 & 4 \\ -4 & 6 & -2 \\ 4 & -2 & 6 \end{bmatrix} = \begin{bmatrix} 6 & -2 & 2 \\ -2 & 3 & -1 \\ 2 & -1 & 3 \end{bmatrix}$$

Now $P^T = P$ so $P = \frac{1}{2}(A + A^T)$ is a symmetric Matrix.

Also let $Q = \frac{1}{2}(A - A^T) = \frac{1}{2} \begin{bmatrix} 0 & 0 & 0 \\ 0 & 0 & 0 \\ 0 & 0 & 0 \end{bmatrix} = \begin{bmatrix} 0 & 0 & 0 \\ 0 & 0 & 0 \\ 0 & 0 & 0 \end{bmatrix}$

$Q^T = -Q$ Hence Q is an Skew Symmetric Matrix.

Now $P + Q = \begin{bmatrix} 6 & -2 & 2 \\ -2 & 3 & -1 \\ 2 & -1 & 3 \end{bmatrix} + \begin{bmatrix} 0 & 0 & 0 \\ 0 & 0 & 0 \\ 0 & 0 & 0 \end{bmatrix} = \begin{bmatrix} 6 & -2 & 2 \\ -2 & 3 & -1 \\ 2 & -1 & 3 \end{bmatrix} = A$

Thus, A is represented as the sum of a symmetric and skew symmetric matrix.

Solving System of Linear Equations by Matrix Method

Step 1. Write the given system of equation in the form of $A X = B$

Step2. Find $|A|$

Step3. Find $\text{adj}(A)$

Step4. Find $A^{-1} = \frac{\text{adj}(A)}{|A|}$

Step5. Find $X = A^{-1}B$

Step6 Find the value of x, y and z

Consistent system: A system of equations is said to be consistent if its solution (one or more) exists.

Inconsistent system: A system of equations is said to be inconsistent if its solution does not exist.

Case I: If A is a nonsingular matrix ($|A| \neq 0$), then its inverse exists and system is consistent and has a unique solution.

Case II: (i) If A is a singular matrix, then $|A| = 0$. In this case, we calculate $(\text{adj } A) B$. If $(\text{adj } A) B \neq O$, (O being zero matrix), then solution does not exist and the system of equations is called inconsistent.

(ii) If $(\text{adj } A) B = O$, then system may be either consistent or inconsistent according as the system have either infinitely many solutions or no solution.

Q5. Solve the system of equations $x + 2y - 3z = -4, 2x + 3y + 2z = 2, 3x - 3y - 4z = 11$

Sol. The given system of equation can be written as $A X = B$ where

$$A = \begin{bmatrix} 1 & 2 & -3 \\ 2 & 3 & 2 \\ 3 & -3 & -4 \end{bmatrix} X = \begin{bmatrix} x \\ y \\ z \end{bmatrix} B = \begin{bmatrix} -4 \\ 2 \\ 11 \end{bmatrix}$$

$$\text{Now } |A| = \begin{vmatrix} 1 & 2 & -3 \\ 2 & 3 & 2 \\ 3 & -3 & -4 \end{vmatrix} = -6 + 28 + 45 = 67$$

$$\text{adj}(A) = \begin{bmatrix} -6 & 14 & -15 \\ 17 & 5 & 9 \\ 13 & -8 & -1 \end{bmatrix}^T = \begin{bmatrix} -6 & 17 & 13 \\ 14 & 5 & -8 \\ -15 & 9 & -1 \end{bmatrix} \text{ Now } A^{-1} = \frac{\text{adj}(A)}{|A|} = \frac{1}{67} \begin{bmatrix} -6 & 17 & 13 \\ 14 & 5 & -8 \\ -15 & 9 & -1 \end{bmatrix}$$

$$\text{Hence } X = A^{-1}B = \frac{1}{67} \begin{bmatrix} -6 & 17 & 13 \\ 14 & 5 & -8 \\ -15 & 9 & -1 \end{bmatrix} \begin{bmatrix} -4 \\ 2 \\ 11 \end{bmatrix} = \frac{1}{67} \begin{bmatrix} 24 + 34 + 143 \\ -56 + 10 - 88 \\ 60 + 18 - 11 \end{bmatrix}$$

$$\text{So } \begin{bmatrix} x \\ y \\ z \end{bmatrix} = \frac{1}{67} \begin{bmatrix} 201 \\ -134 \\ 67 \end{bmatrix} = \begin{bmatrix} 3 \\ -2 \\ 1 \end{bmatrix}$$

Hence $x = 3, y = -2, z = 1$

ASSIGNMENTS

Multiple choice questions

Choose the correct option

1. The matrix $P = \begin{pmatrix} 0 & 0 & 4 \\ 0 & 4 & 0 \\ 4 & 0 & 0 \end{pmatrix}$ is a

(a) square matrix (b) diagonal matrix (c) Unit Matrix (c) none of these

2. Total number of possible matrix of order 3×3 with each entry 2 or 0 is

(a) 9 (b) 27 (c) 81 (d) 512

3. If A and B are two matrices of order $3 \times m$ and $3 \times n$ respectively, and $m=n$, then the order of the matrix $(5A-2B)$ is

(a) $m \times 3$ (b) 3×3 (c) $m \times n$ (d) $3 \times n$

4. If A and B are matrices are of the same order then $(AB' - BA')$ is a

(a) skew symmetric matrix (b) null matrix (c) symmetric matrix (d) unit matrix

5. Let A be a square matrix of order 3×3 , then $|kA|$ equal to

(a) $k|A|$ (b) $k^2|A|$ (c) $k^3|A|$ (d) $3k|A|$

6. Which of the following is correct

(a) Determinant is a square matrix

(b) Determinant is a number associated to a matrix

© Determinant is a number associated to a square matrix.

(d) None of these

Answer:

1.a 2.d 3.d 4.a 5.c

VERY SHORT ANSWER TYPE QUESTIONS(VSA-2 MARKS)

1. If a matrix has 6 elements, what are the possible orders it can have?

2. Construct a 3×2 matrix whose elements are given by $a_{ij} = |i - 3j|$

3. If $A = \begin{bmatrix} 1 & 2 & 3 \\ 3 & 1 & 3 \end{bmatrix}$, $B = \begin{bmatrix} 2 & 3 & 1 \\ 1 & 0 & 2 \end{bmatrix}$, then find $A - 2B$.

4. If $A = \begin{bmatrix} 2 & 1 & 4 \\ 4 & 1 & 5 \end{bmatrix}$ and $B = \begin{bmatrix} 3 & -1 \\ 2 & 2 \\ 1 & 3 \end{bmatrix}$, write the order of AB and BA.

5. Find the matrices X and Y if $X + Y = \begin{bmatrix} 5 & 2 \\ 0 & 9 \end{bmatrix}$ and $X - Y = \begin{bmatrix} 3 & 6 \\ 0 & -1 \end{bmatrix}$

6. Solve: $\begin{bmatrix} x & 1 \\ -2 & -3 \end{bmatrix} \begin{bmatrix} 1 & 0 \\ -2 & -3 \end{bmatrix} \begin{bmatrix} x \\ 3 \end{bmatrix} = 0$.

7. Find the co-factor of a_{12} in $A = \begin{vmatrix} 2 & -3 & 5 \\ 6 & 0 & 4 \\ 1 & 5 & -7 \end{vmatrix}$

8. Find the adjoint of the matrix $A = \begin{bmatrix} 2 & -1 \\ 4 & 3 \end{bmatrix}$

9. If $A = \begin{bmatrix} 2 & 3 \\ 5 & -2 \end{bmatrix}$, write A^{-1} in terms of A

10. If A is square matrix satisfying $A^2 = I$, then what is the inverse of A ?

11. For what value of k , the matrix $A = \begin{bmatrix} 2-k & 3 \\ -5 & 1 \end{bmatrix}$ is not invertible?

12. Evaluate $\begin{vmatrix} \cos 15^\circ & \sin 15^\circ \\ \sin 75^\circ & \cos 75^\circ \end{vmatrix}$

13. What is the value of $|3I|$, where I is identity matrix of order 3?

14. If A is non singular matrix of order 3 and $|A| = 3$, then find $|2A|$

15. For what value of a , $\begin{bmatrix} 2a & -1 \\ -8 & 3 \end{bmatrix}$ is a singular matrix?

Answer:

1. $1 \times 6, 6 \times 1, 2 \times 3, 3 \times 2$ 2. $\begin{bmatrix} 1 & 5 \\ \frac{1}{2} & 2 \\ 0 & \frac{3}{2} \end{bmatrix}$ 3. $\begin{bmatrix} -3 & -4 & 1 \\ 1 & 1 & -1 \end{bmatrix}$ 4. $2 \times 2, 3 \times 3$

7. 46 8. $\begin{bmatrix} 3 & 1 \\ -4 & 2 \end{bmatrix}$

9. $A^{-1} = -A$ 10. $A^{-1} = A$ 11. $k = 17$, 12. 0 13. 27 14. 24 15. $-4/3$

SHORT ANSWER TYPE QUESTIONS (SA-3 MARKS)

1. For the following matrices A and B , verify $(AB)^T = B^T A^T$, where $A = \begin{bmatrix} 1 \\ -4 \\ 3 \end{bmatrix}$, $B = \begin{bmatrix} -1 & 2 & 1 \end{bmatrix}$.

2. Give example of matrices A & B such that $AB = O$, but $BA \neq O$, where O is a zero matrix and A, B are both non zero matrices.

3. If B is skew symmetric matrix, write whether the matrix (ABA^T) is symmetric or skew symmetric.

4. If $A = \begin{bmatrix} 3 & 1 \\ 7 & 5 \end{bmatrix}$ and $I = \begin{bmatrix} 1 & 0 \\ 0 & 1 \end{bmatrix}$, find a and b so that $A^2 + aI = bA$

5. Verify $A(\text{adj}A) = (\text{adj}A)A = |A|I$ if

$$1. A = \begin{bmatrix} 2 & 3 \\ -4 & -6 \end{bmatrix} \qquad 2. A = \begin{bmatrix} 1 & 2 & 3 \\ 2 & 3 & 2 \\ 3 & 3 & 4 \end{bmatrix}$$

6. If $A = \begin{bmatrix} 3 & -5 \\ -4 & 2 \end{bmatrix}$, show that $A^2 - 5A - 14I = 0$. Hence find A^{-1}

7. If A, B, C are three non-zero square matrices of same order, find the condition on A such that $AB = AC \Rightarrow B = C$.

8. Find the number of all possible matrices A of order 3×3 with each entry 0 or 1.

9. If A is a square matrix of order 3 such that $|adjA| = 64$, find $|A|$

10. If A is a nonsingular matrix of order 3 and $|A| = 7$, then find $|adjA|$

11. If $A = \begin{bmatrix} a & 2 \\ 2 & a \end{bmatrix}$ and $|A|^3 = 125$, then find a.

12. A square matrix A, of order 3, has $|A| = 5$, find $|A \cdot adjA|$

13. Find positive value of x if $\begin{vmatrix} 16 & 3 \\ 5 & 2 \end{vmatrix} = \begin{vmatrix} 2x & 3 \\ 5 & x \end{vmatrix}$

14. Evaluate $\begin{vmatrix} a+ib & c+id \\ -c+id & a-ib \end{vmatrix}$

Answer:

3. skew symmetric 4. $a = 8, b = 8, 6.$ $\begin{bmatrix} -\frac{2}{14} & -\frac{5}{14} \\ -\frac{4}{14} & -\frac{3}{14} \end{bmatrix}$ 8.512 9.8 10.49

11. $a = \pm 33$ 12. 125 13.4 14. $a^2 + b^2 + c^2 + d^2$

LONG ANSWER TYPE QUESTIONS (LA-5 MARKS)

1. If $A = \begin{bmatrix} 2 & 0 & 1 \\ 2 & 1 & 3 \\ 1 & -1 & 0 \end{bmatrix}$, then find the value of $A^2 - 3A + 2I$

2. Express the matrix A as the sum of a symmetric and a skew symmetric matrix, where:

$$A = \begin{bmatrix} 3 & -2 & -4 \\ 3 & -2 & -5 \\ -1 & 1 & 2 \end{bmatrix}$$

3. If $A = \begin{bmatrix} \cos\theta & \sin\theta \\ -\sin\theta & \cos\theta \end{bmatrix}$ then prove that $A^n = \begin{bmatrix} \cos n\theta & \sin n\theta \\ -\sin n\theta & \cos n\theta \end{bmatrix}, n \in \mathbb{N}$

4. If $A = \begin{bmatrix} 2 & 3 & 1 \\ -3 & 2 & 1 \\ 5 & -4 & -2 \end{bmatrix}$, find A^{-1} and hence solve the following system of equations: $2x - 3y + 5z = 11$, $3x + 2y - 4z = -5$, $x + y - 2z = -3$.

5. Using matrices solve the following system of equations:

(i) $x + 2y - 3z = -4$, $2x + 3y + 2z = 2$, $3x - 3y - 4z = 11$

(ii) $4x + 3y + 2z = 60$, $x + 2y + 3z = 45$, $6x + 2y + 3z = 70$

6. Find the product AB , where $A = \begin{bmatrix} 1 & -1 & 0 \\ 2 & 3 & 4 \\ 0 & 1 & 2 \end{bmatrix}$, $B = \begin{bmatrix} 2 & 2 & -4 \\ -4 & 2 & -4 \\ 2 & -1 & 5 \end{bmatrix}$ and use it to solve the equations $x - y = 3$, $2x + 3y + 4z = 17$, $y + 2z = 7$

$$\frac{1}{x} - \frac{1}{y} + \frac{1}{z} = 4$$

7. Using matrices solve the following system of equations: $\frac{2}{x} + \frac{1}{y} - \frac{3}{z} = 0$

$$\frac{1}{x} + \frac{1}{y} + \frac{1}{z} = 2$$

8. A trust caring for indicate children gets rupees 30,000/- every month from its donors. The trust spends half of the funds received for medical and educational care of the children and for that it charges 2% of the spent amount from them and deposits the balance note in a private bank to get the money multiplied so that in future the trust goes on functioning regularly. What % of interest should the trust get from the bank to get a total of rupees 1800/- every month? Use matrix method to find the rate of interest? Do u think people should donate to such trusts?

Answer: 1. $\begin{bmatrix} 1 & -1 & -1 \\ 3 & -3 & 4 \\ -3 & 2 & 0 \end{bmatrix}$ 2. $\begin{bmatrix} 3 & \frac{1}{2} & -\frac{5}{2} \\ \frac{1}{2} & -2 & -2 \\ -\frac{5}{2} & -2 & 2 \end{bmatrix} + \begin{bmatrix} 0 & -\frac{5}{2} & -\frac{3}{2} \\ \frac{5}{2} & 0 & -3 \\ \frac{3}{2} & 3 & 0 \end{bmatrix}$

4. $x = 1$, $y = 2$, $z = 3$. 5. (i) $x = 3$, $y = -2$, $z = 1$. (ii) $x = 7$, $y = 4$, $z = 10$

6. $AB = 6I$, $x = 2$, $y = -1$, $z = 4$ 7. $x = \frac{1}{2}$, $y = -1$, $z = 1$

COMPETENCY BASED QUESTIONS

1. Two farmers Ramkrishan and Gurucharan Singh cultivate only three varieties of rice namely Basmati, Permal and Naura. The sale (in Rupees) of these varieties of rice by both the farmers in the month of September and October are given by the following matrices A and B.

September Sales (In rupees):

$$\begin{bmatrix} \text{Basmati} & \text{Permal} & \text{Naura} \\ 10,000 & 20,000 & 30,000 \\ 50,000 & 30,000 & 10,000 \end{bmatrix} \begin{matrix} \text{Ramakrisan} \\ \text{Gurucharan Singh} \end{matrix}$$

October Sales (In rupees):

$$\begin{bmatrix} \text{Basmati} & \text{Permal} & \text{Naura} \\ 50,000 & 10,000 & 6,000 \\ 20,000 & 10,000 & 10,000 \end{bmatrix} \begin{matrix} \text{Ramakrisan} \\ \text{Gurucharan Singh} \end{matrix}$$

On the basis of above information answer the following questions

- (i) What is the order of the matrix $A \times B$?
- (ii) If a_{ij} is the element of the matrix A and if b_{ij} is the element of matrix B, then what is the result of $a_{23} \times b_{22}$?
- (iii) Find the combined sale in September and October for each farmer and each variety.

OR

(iii) Find the decrease in sales from September to October

2. Rahul wants to invest Rs30,000 in two different types of bonds. The first bond pay 5% p.a. interest while other will give 7%. If Rahul will get Rs1800/- annual interest.

On the basis of this information answer the following questions

- (i) Represent the given condition in matrix form
- (ii) What amount the Rahul will invest at 5% pa interest rate
- (iii) What amount the Rahul will invest at 7% pa interest rate

OR

(iii) He if invests Rs15000 for two years at 7% per annum simple interest, then how much interest will he get

3. Manjit wants to donate a rectangular plot of land for a school in his village. When he was asked to give dimensions of the plot, he told that if its length is by 50m and breath is increased by 50m, then its area will remain same, but if length is decreased by 10m and breath is decreased by 20m then its area will decrease by 5300m².

Based on the information given above answer the following questions

- (i) Find the equation in terms of x and y .
- (ii) Write the equation in matrix form.
- (iii) Find the length of the rectangular plot
- (iii) How much is the area of rectangular field

OR

Answers of Competency based questions

1.(i) not defined

(ii) $(10000)^2$

$$(iii) \begin{bmatrix} \text{Basmati} & \text{Permal} & \text{Naura} \\ 15,000 & 30,000 & 36,000 \\ 70,000 & 40,000 & 20,000 \end{bmatrix} \begin{matrix} \text{Ramakrisan} \\ \text{Gurucharan Singh} \end{matrix}$$

OR

$$(iii) \begin{bmatrix} 5,000 & 10,000 & 24,000 \\ 30,000 & 20,000 & 0 \end{bmatrix} \begin{matrix} \text{Ramakrisan} \\ \text{Gurucharan Singh} \end{matrix}$$

15. (i) $[x \quad 30,000 - 2x] \begin{bmatrix} 7\% \\ 5\% \end{bmatrix} = 1800$

(ii) 15000 (iii) 15000

OR

(iii) 2100

16. (i) $X - y = 50, 2x + y = 50$

$$(ii) \begin{bmatrix} 1 & -1 \\ 2 & 1 \end{bmatrix} \begin{bmatrix} x \\ y \end{bmatrix} = \begin{bmatrix} 50 \\ 550 \end{bmatrix}$$

(iii) 200m

OR

(iv) 30000 sq.m

KENDRIYA VIDYALAYA SANGATHAN, RAIPUR REGION (2022-23)
CLASS XII – MATHEMATICS

CHAPTER 5- CONTINUITY AND DIFFERENTIABILITY

COUNTINUITY OF A FUNCTION

LEARNING OBJECTIVES/OUTCOMES

Understanding the concept of Continuity and differentiability and addressing the problems based on continuity

and derivative of composite functions, chain rule, derivatives of inverse trigonometric functions, derivative of

implicit functions.

Learning the concept of exponential and logarithmic functions.

Skills to solve derivatives of logarithmic and exponential function. Logarithmic differentiation, derivative of

functions expressed in parametric forms. Second order derivatives

Knowledge of functions :

(i) Polynomial functions: e.g. $f(x) = x^2 + 2x + 5$

(ii) Modulus function : $f(x) = |x|$

(iii) Greatest Integer Function : $f(x) = [x]$

(iv) Signum function : The signum function, denoted sgn , is defined as follows: $sgn(x) = \{ 1, x > 0$
 $-1, x < 0$ $0, x = 0$

(v) Trigonometric functions : $\sin x, \cos x$ etc.

(vi) Inverse Trigonometric functions : $\sin^{-1} x, \cos^{-1} x$ etc.

(vii) Logarithmic functions : $f(x) = \log x$

(viii) Exponential functions : $f(x) = e^x$.

DEFINITION OF CONTINUITY

Continuity at a Point: A function $f(x)$ is said to be continuous at a point $x = a$, if

Left hand limit of $f(x)$ at $(x = a) =$ Right hand limit of $f(x)$ at $(x = a) =$ Value of $f(x)$ at $(x = a)$

i.e. if at $x = a$, $LHL = RHL = f(a)$

where, $LHL = \lim_{x \rightarrow a^-} f(x)$ and $RHL = \lim_{x \rightarrow a^+} f(x)$

Note: To evaluate LHL of a function $f(x)$ at $(x = a)$, put $x = a - h$ and to find RHL, put $x = a + h$.

Continuity in an Interval: A function $y = f(x)$ is said to be continuous in an interval (a, b) , where $a < b$ if and only if $f(x)$ is continuous at every point in that interval.

- Every identity function is continuous.
- Every constant function is continuous.
- Every polynomial function is continuous.
- Every rational function is continuous.
- All trigonometric functions are continuous in their domain..

Algebra of Continuous Functions

Suppose f and g are two real functions, continuous at real number c . Then,

- $f + g$ is continuous at $x = c$.
- $f - g$ is continuous at $x = c$.
- $f \cdot g$ is continuous at $x = c$.
- cf is continuous, where c is any constant.
- $(f \circ g)$ is continuous at $x = c$, [provide $g(c) \neq 0$]

NOTE- Suppose f and g are two real valued functions such that $(f \circ g)$ is defined at c . If g is continuous at c and f is continuous at $g(c)$, then $(f \circ g)$ is continuous at c .

- If f is continuous, then $|f|$ is also continuous.

Standard Results of Limits

$$\begin{aligned} \text{(i)} \quad \lim_{x \rightarrow a} \frac{x^n - a^n}{x - a} &= na^{n-1} & \text{(ii)} \quad \lim_{x \rightarrow 0} \frac{\sin x}{x} &= 1 & \text{(iii)} \quad \lim_{x \rightarrow 0} \frac{\tan x}{x} &= 1 \\ \text{(iv)} \quad \lim_{x \rightarrow 0} \frac{e^x - 1}{x} &= 1 & \text{(v)} \quad \lim_{x \rightarrow \infty} \frac{1}{x^p} &= 0, p \in (0, \infty) & \text{(vi)} \quad \lim_{x \rightarrow 0} \frac{\log(1+x)}{x} &= 1 \\ \text{(vii)} \quad \lim_{x \rightarrow 0} \frac{a^x - 1}{x} &= \log_e a & \text{(viii)} \quad \lim_{x \rightarrow 0} \frac{\sin^{-1} x}{x} &= 1 & \text{(x)} \quad \lim_{x \rightarrow 0} (1+x)^{1/x} &= e \\ \text{(xi)} \quad \lim_{x \rightarrow \infty} \frac{\sin x}{x} &= 0 & \text{(xii)} \quad \lim_{x \rightarrow \infty} \left(1 + \frac{1}{x}\right)^x &= e \\ \text{(xiii)} \quad \lim_{x \rightarrow \infty} \sin x &= \lim_{x \rightarrow \infty} \cos x &= \text{lies between } -1 \text{ to } 1. \end{aligned}$$

Differentiability

- 1) The derivative of the function f at the point a in its domain is given by $f'(a) = \lim_{h \rightarrow 0} \frac{f(a+h) - f(a)}{h}$
- 2) The function f is differentiable at the point a in its domain if $f'(a)$ exists.
- 3) The function f is differentiable on the subset S of its domain if it is differentiable at each point of S .

OR

Differentiability: A function $f(x)$ is said to be differentiable at a point $x = a$, if
Left hand derivative at $(x = a) =$ Right hand derivative at $(x = a)$
i.e. LHD at $(x = a) =$ RHD (at $x = a$), where Right hand derivative, where

$$\text{Right hand derivative, } Rf'(a) = \lim_{h \rightarrow 0} \frac{f(a+h) - f(a)}{h}$$

$$\text{Left hand derivative, } Lf'(a) = \lim_{h \rightarrow 0} \frac{f(a-h) - f(a)}{-h}$$

A function can fail to be differentiable at a point a if either $\lim_{h \rightarrow 0} \frac{f(a+h) - f(a)}{h}$ does not exist, or is infinite

Note :

(a) All continuous functions are differentiable. For instance, the closed-form function $f(x) = |x|$ is continuous at every real number (including $x = 0$), but not differentiable at $x = 0$. (b) However, every differentiable function is continuous.

Note: Every differentiable function is continuous but every continuous function is not differentiable.

Differentiation: The process of finding a derivative of a function is called differentiation.

Rules of Differentiation :

Sum and Difference Rule: Let $y = f(x) \pm g(x)$. Then, by using sum and difference rule, its derivative

is written as

$$\frac{dy}{dx} = \frac{d}{dx} f(x) \pm \frac{d}{dx} g(x).$$

Product Rule: Let $y = f(x)g(x)$. Then, by using product rule, it's derivative is written as

$$\frac{dy}{dx} = \left[\frac{d}{dx} (f(x)) \right] g(x) + \left[\frac{d}{dx} (g(x)) \right] f(x).$$

Quotient Rule: Let $y = f(x)/g(x)$; $g(x) \neq 0$, then by using quotient rule, it's derivative is written as

$$\frac{dy}{dx} = \frac{g(x) \times \frac{d}{dx} [f(x)] - f(x) \times \frac{d}{dx} [g(x)]}{[g(x)]^2}.$$

Chain Rule: Let $y = f(u)$ and $u = f(x)$, then by using chain rule, we may write

$$\frac{dy}{dx} = \frac{dy}{du} \cdot \frac{du}{dx}, \text{ when } \frac{dy}{du} \text{ and } \frac{du}{dx} \text{ both exist.}$$

Rules of logarithmic function

$$\log mn = \log m + \log n$$

$$\log \left(\frac{m}{n} \right) = \log m - \log n$$

$$\log (m^n) = n \log m$$

$$\text{Change of base rule, } \log_a b = \frac{\log_e b}{\log_e a}$$

$$\log_e e = 1, \log_e 1 = 0, e^{\log_e f(x)} = f(x)$$

Differentiation of Functions in Parametric Form: A relation expressed between two variables x and y in the form $x = f(t)$, $y = g(t)$ is said to be parametric form with t as a parameter, when

$$\frac{dy}{dx} = \frac{\left(\frac{dy}{dt} \right)}{\left(\frac{dx}{dt} \right)}$$

(whenever $dx/dt \neq 0$)

Note: dy/dx is expressed in terms of parameter only without directly involving the main variables x and y .

Second order Derivative: It is the derivative of the first order derivative.

$$\frac{d^2 y}{dx^2} = \frac{d}{dx} \left(\frac{dy}{dx} \right)$$

Some Standard Derivatives

- | | |
|---|--|
| (i) $\frac{d}{dx}(\sin x) = \cos x$ | (ii) $\frac{d}{dx}(\cos x) = -\sin x$ |
| (iii) $\frac{d}{dx}(\tan x) = \sec^2 x$ | (iv) $\frac{d}{dx}(\sec x) = \sec x \tan x$ |
| (v) $\frac{d}{dx}(\operatorname{cosec} x) = -\operatorname{cosec} x \cot x$ | (vi) $\frac{d}{dx}(\cot x) = -\operatorname{cosec}^2 x$ |
| (vii) $\frac{d}{dx}(\sin^{-1} x) = \frac{1}{\sqrt{1-x^2}}$ | (viii) $\frac{d}{dx}(\cos^{-1} x) = \frac{-1}{\sqrt{1-x^2}}$ |
| (ix) $\frac{d}{dx}(\tan^{-1} x) = \frac{1}{1+x^2}$ | (x) $\frac{d}{dx}(\sec^{-1} x) = \frac{1}{x\sqrt{x^2-1}}$ |
| (xi) $\frac{d}{dx}(\operatorname{cosec}^{-1} x) = \frac{-1}{x\sqrt{x^2-1}}$ | (xii) $\frac{d}{dx}(\cot^{-1} x) = \frac{-1}{1+x^2}$ |
| (xiii) $\frac{d}{dx}(x^n) = nx^{n-1}$ | (xiv) $\frac{d}{dx}(\text{constant}) = 0$ |
| (xv) $\frac{d}{dx}(e^x) = e^x$ | (xvi) $\frac{d}{dx}(\log_e x) = \frac{1}{x}, x > 0$ |
| (xvii) $\frac{d}{dx}(a^x) = a^x \log_e a, a > 0$ | |

Some Useful Substitutions for Finding Derivatives Expression

Expression	Substitution
(i) $a^2 + x^2$	$x = a \tan \theta$ or $x = a \cot \theta$
(ii) $a^2 - x^2$	$x = a \sin \theta$ or $x = a \cos \theta$
(iii) $x^2 - a^2$	$x = a \sec \theta$ or $x = a \operatorname{cosec} \theta$
(iv) $\sqrt{\frac{a-x}{a+x}}$ or $\sqrt{\frac{a+x}{a-x}}$	$x = a \cos 2\theta$
(v) $\sqrt{\frac{a^2-x^2}{a^2+x^2}}$ or $\sqrt{\frac{a^2+x^2}{a^2-x^2}}$	$x^2 = a^2 \cos 2\theta$

Logarithmic Differentiation: Let $y = [f(x)]^{g(x)}$..(i)

So by taking log (to base e) we can write Eq. (i) as $\log y = g(x) \log f(x)$. Then, by using chain rule

$$\frac{dy}{dx} = [f(x)]^{g(x)} \left[\frac{g(x)}{f(x)} f'(x) + g'(x) \log f(x) \right]$$

SECTION –A (MULTIPLE CHOICE QUESTIONS)

1.The value of b for which the function $f(x) = \begin{cases} 5x - 4, & 0 < x \leq 1 \\ 4x^2 + 3bx, & 1 < x < 2 \end{cases}$ is continuous at every point of its domain is

- (a) -1 (b) 0 (c) 13/3 (d) 1

2.The points of discontinuity of the function $f(x) = \begin{cases} 2\sqrt{x}, & 0 \leq x \leq 1 \\ 4 - 2x, & 1 < x < \frac{5}{2} \\ 2x - 7, & \frac{5}{2} \leq x \leq 4 \end{cases}$ is (are)

- (a) x = 1, 5/2 (b) x =5/2 (c) x= 1,5/2,4 (d) x =0,4

3.The set of points where the function f(x) given by $f(x) = |x-3| \cos x$ is differentiable is

- (a) R (b) R- {3} (c) (0,∞) (d) (-∞,0)

4.Rolle's theorem is not applicable for $f(x) = |x|$ in [-2,2] because

- (a) f is not continuous in [-2,2] (b) f is not derivable in (-2,2) (c) $f(2) \neq f(-2)$ (d) none of these

5.If $f(x) = \begin{cases} \frac{1}{1+e^x}, & x \neq 0 \\ 0, & x = 0 \end{cases}$, then f(x) is

- (a) continuous as well as differentiable at x=0 (b) continuous but not differentiable at x=0 (c) differentiable But not continuous at x=0 (d) none of these

6.If $y^2 = ax^2 + b$, then $\frac{d^2y}{dx^2} =$

- (a) $\frac{ab}{x^3}$ (b) $\frac{x^3}{ab}$ (c) $\frac{ab}{y^2}$ (d) $\frac{ab}{y^3}$

7.The function $f(x) = | \cos x |$ is

- (a) differentiable at $x = (2n+1) \pi/2, n \in Z$ (b) continuous but not differentiable at $x = (2n+1) \pi/2, n \in Z$
(c) differentiable for all x but not continuous at some x (d) None of these

8. If the function f(x) defined by $f(x) = \begin{cases} \frac{\log(1+3x) - \log(1-2x)}{x}, & x \neq 0 \\ k, & x = 0 \end{cases}$ is continuous at x=0 then k =

- (a) 1 (b) 5 (c) -1 (d) none of these

9.if $f(x) = \begin{cases} a \sin \frac{\pi}{2}(x+1), & x \leq 0 \\ \frac{\tan x - \sin x}{x^3}, & x > 0 \end{cases}$ is continuous at x=0 then a =

- (a) 1/2 (b) 1/3 (c) 1/4 (d) 1/6

10.The function $f(x) = x - [x]$, where [x] denotes the greatest integer function is

- (a) continuous at integer points only (b) continuous at everywhere (c) continuous at noninteger points only
(d) differentiable everywhere

Ans: 1)a 2)b 3)b 4)b 5)d 6) d 7)b 8)b 9)b 10)a

VERY SHORT ANSWER QUESTIONS: (2 MARKS EACH)

1. At what points is the function given by $(x) = x+1(x-2)(x-3)$ is continuous?

(Ans; 2,3) .

2. If the function $(x) = \text{Sin } 10x/x, x \neq 0$ is continuous at $x=0$, find $f(0)$. (Ans. 10)

3. Check the continuity of $f(x) = 2x + 3$ at $x = 1$.

4. Discuss the continuity of the function $f(x) = |x|$ at $x = 0$.

5. Show that $f(x) = 2x - |x|$ is continuous at $x = 0$.
6. Find the derivative of $\sec^{-1}\left(\frac{1}{2x^2-1}\right)$ w.r.t. $\sqrt{1-x^2}$ at $x = \frac{1}{2}$ Ans: 4
7. Differentiate $\tan^{-1}\left(\frac{1+\cos x}{\sin x}\right)$ with respect to x . Ans: $-\frac{1}{2}$
8. Find the derivative of $f(e^{\tan x})$ w. r. to $x = 0$. It is given that $f'(1) = 5$
Ans: 5
9. If $y = P e^{ax} + Q e^{bx}$, show that $\frac{d^2y}{dx^2} - (a+b) \frac{dy}{dx} + a b y = 0$
10. Find the value of k so that the function f is continuous at $x = \frac{\pi}{2}$

$$f(x) = \begin{cases} \frac{k \cos x}{\pi - 2x}, & \text{if } x \neq \frac{\pi}{2} \\ 5, & \text{if } x = \frac{\pi}{2} \end{cases} \quad \text{Ans: } k = 10$$

SHORT ANSWER QUESTIONS : Three marks questions

11. If $y = e^{a \cos^{-1} x}$, $-1 \leq x \leq 1$ then show that: $(1-x^2) \frac{d^2y}{dx^2} - x \frac{dy}{dx} - a^2 y = 0$
12. Determine the value of 'k' for which the following function is continuous at $x = 3$,
 $f(x) = \begin{cases} \frac{(x+3)^2 - 36}{x-3}, & x \neq 3 \\ k, & x = 3 \end{cases}$ Ans: $k = 12$
13. If $x = a \sin pt$, $y = b \cos pt$, Then find $\frac{d^2y}{dx^2}$ at $t = 0$ Ans: $-\frac{b}{a^2}$
14. If $x = 3 \sin t - \sin 3t$ and $y = 3 \cos t - \cos 3t$, find $\frac{d^2y}{dx^2}$ at $t = \frac{\pi}{3}$ Ans: $\frac{-16}{27}$
15. Show that $f(x) = |x - 3|$, $\forall x \in \mathbb{R}$, is continuous but not differentiable at $x = 3$
16. If $y = (\tan^{-1} x)^2$, show that $(x^2 + 1)^2 \cdot \frac{d^2y}{dx^2} + 2x(x^2 + 1) \frac{dy}{dx} = 2$
17. If $x^y = e^{x-y}$, then show that $\frac{dy}{dx} = \frac{\log x}{\{\log(xe)\}^2}$
18. If $\cos y = x \cos(a + y)$, with $\cos a \neq \pm 1$, prove that $\frac{dy}{dx} = \frac{\cos^2(a+y)}{\sin a}$
19. Differentiate the following with respect to x : $\sin^{-1}\left(\frac{2^{x+1} \cdot 3^x}{1+(36)^x}\right)$ Ans: $\frac{2^{x+1} \cdot 3^x \log 6}{1+36^x}$
20. Differentiate the following with respect to x : $\sin^{-1}\left(\frac{2^{x+1}}{1+(4)^x}\right)$ Ans: $\frac{2^{x+1} \cdot \log 2}{1+4^x}$

SECTION D : Five marks questions

21. If $x^y + y^x = a^b$, then find $\frac{dy}{dx}$ Ans: $-\frac{yx^{y-1} + y^x \log y}{x^y \log x + xy^{x-1}}$
22. If $f(x) = \begin{cases} \frac{\sin(a+1)x + 2 \sin x}{x}, & x < 0 \\ 2, & x = 0 \\ \frac{(\sqrt{1+bx}-1)}{x}, & x > 0 \end{cases}$ is continuous at $x = 0$, then find the values of a and b .
Ans: $a = -1, b = 4$

23. Find the value of k, for which $f(x) = \begin{cases} \frac{\sqrt{1+kx}-\sqrt{1-kx}}{x}, & \text{if } -1 \leq x < 0 \\ \frac{2x+1}{x-1}, & \text{if } 0 \leq x < 1 \end{cases}$ is continuous at

$x = 0$ Ans: $k = -2$

24. If $x = \tan\left(\frac{1}{a} \log y\right)$, show that $(1+x^2) \frac{d^2y}{dx^2} + (2x-a) \frac{dy}{dx} = 0$

25. If $y\sqrt{x^2+1} = \log(\sqrt{x^2+1}-x)$, then show that $(x^2+1) \frac{dy}{dx} + xy + 1 = 0$

26. Find the values of a and b, if the function f is defined by

$$f(x) = \begin{cases} x^2 + 3x + a, & x \leq 1 \\ bx + 2, & x > 1 \end{cases} \text{ is differentiable at } x = 1$$

Ans: $a =$

$3, b = 5$

27. Show that the function f given by :

$$f(x) = \begin{cases} \frac{1}{e^x-1} & \text{if } x \neq 0 \\ -1 & \text{if } x = 0 \end{cases} \text{ is discontinuous at } x = 0$$

28. Find, $\frac{dy}{dx}$ of the function $y = (\log x)^x + x^{\sin x}$

$$\text{Ans: } (\log x)^x \left[\log(\log x) + \frac{1}{\log x} \right] + x^{\sin x} \left(\frac{\sin x}{x} + \cos x \cdot \log x \right)$$

ASSERTION BASED QUESTION

TOIPC -CONTINUTY AND DIFFERENTIABILITY

DIRECTION: In the following questions, as statement of assertion (A) is followed by a statement of reason (R). Mark the correct choice as:

- Both assertion (A) and reason (R) are true and reason (R) is the correct explanation of assertion (A)
- Both assertion (A) and reason (R) are true and reason (R) is not the correct explanation of assertion (A)
- Assertion (A) is true but reason (R) is false.
- Assertion (A) is false but reason (R) is true.
- Both Assertion (A) and reason (R) are false.

- Assertion (A): $f(x) = \tan^2 x$
Reason (R): x^2 is continuous at $x = \frac{\pi}{2}$
- Assertion (A): $f(x) = |\sin x|$ is continuous for all $x \in \mathbb{R}$
Reason (R): $\sin x$ and $|x|$ are continuous at on \mathbb{R} .
- Assertion (A): $f(x) = |\sin x|$ is continuous $x=0$.
Reason (R): $|\sin x|$ is differentiable at $x=0$.
- Assertion (A): $f(x) = [x]$ is not differentiable at $x=2$.
Reason (R): $f(x) = [x]$ is not continuous at $x=2$.

5. **Assertion(A): A continuous function is always differentiable.**
Reason(R):A differentiable function is always continuous.
6. **Assertion(A):If $y=\log\sqrt{\tan x}$,then the value of**
Reason(R):The value of $\log 1$ is not defined.

KENDRIYA VIDYALAYA SANGATHAN, RAIPUR REGION (2022-23)
CLASS XII –MATHEMATICS

CHAPTER-6
Application of derivatives

- **RATE OF CHANGE OF DERIVATIVES**

Rate of Change of Quantities: Let $y = f(x)$ be a function of x . Then, dy/dx represents the rate of change of y with respect to x .

If two variables x and y are varying with respect to another variable t , i.e. $x = f(t)$ and $y = g(t)$, then

$$\frac{dy}{dx} = \frac{dy}{dt} / \frac{dx}{dt}, \text{ where } \frac{dx}{dt} \neq 0 \text{ (by chain rule)}$$

In other words, the rate of change of y with respect to x can be calculated using the rate of change of y and that of x both with respect to t .

Note: dy/dx is positive, if y increases as x increases and it is negative, if y decreases as x increases, dx

Marginal Cost: Marginal cost represents the instantaneous rate of change of the total cost at any level of output.

If $C(x)$ represents the cost function for x units produced, then marginal cost (MC) is given by

$$MC = \frac{d}{dx} \{C(x)\}$$

Marginal Revenue: Marginal revenue represents the rate of change of total revenue with respect to the number of items sold at an instant.

If $R(x)$ is the revenue function for x units sold, then marginal revenue (MR) is given by

$$MR = \frac{d}{dx} \{R(x)\}$$

• INCREASING AND DECREASING FUCTION

Let I be an open interval contained in the domain of a real valued function f . Then, f is said to be

- Increasing on I , if $x_1 < x_2$ in $I \Rightarrow f(x_1) \leq f(x_2), \forall x_1, x_2 \in I$.
- Strictly increasing on I , if $x_1 < x_2$ in $I \Rightarrow f(x_1) < f(x_2), \forall x_1, x_2 \in I$.
- Decreasing on I , if $x_1 < x_2$ in $I \Rightarrow f(x_1) \geq f(x_2), \forall x_1, x_2 \in I$.
- Strictly decreasing on I , if $x_1 < x_2$ in $I \Rightarrow f(x_1) > f(x_2), \forall x_1, x_2 \in I$.

Let x_0 be a point in the domain of definition of a real-valued function f , then f is said to be increasing, strictly increasing, decreasing or strictly decreasing at x_0 , if there exists an open interval I containing x_0 such that f is increasing, strictly increasing, decreasing or strictly decreasing, respectively in I .

Note: If for a given interval $I \subseteq R$, function f increase for some values in I and decrease for other values in I , then we say function is neither increasing nor decreasing.

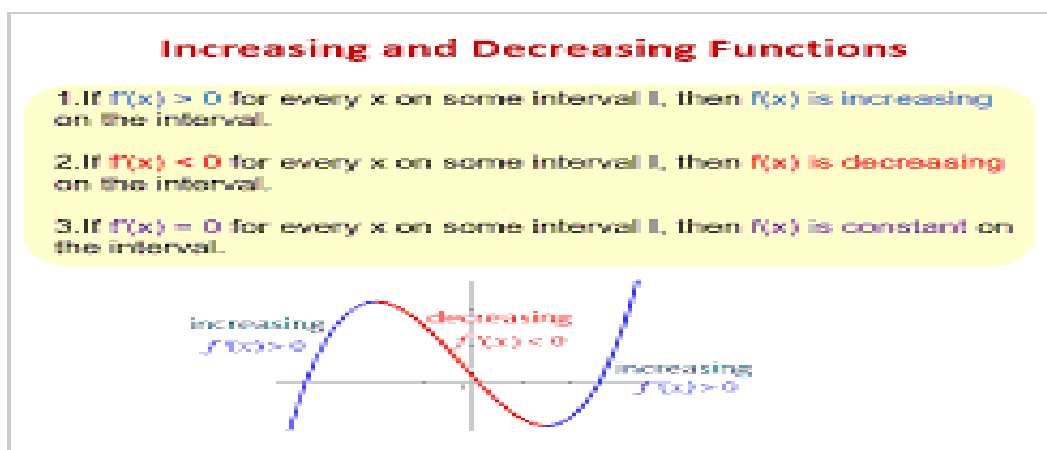

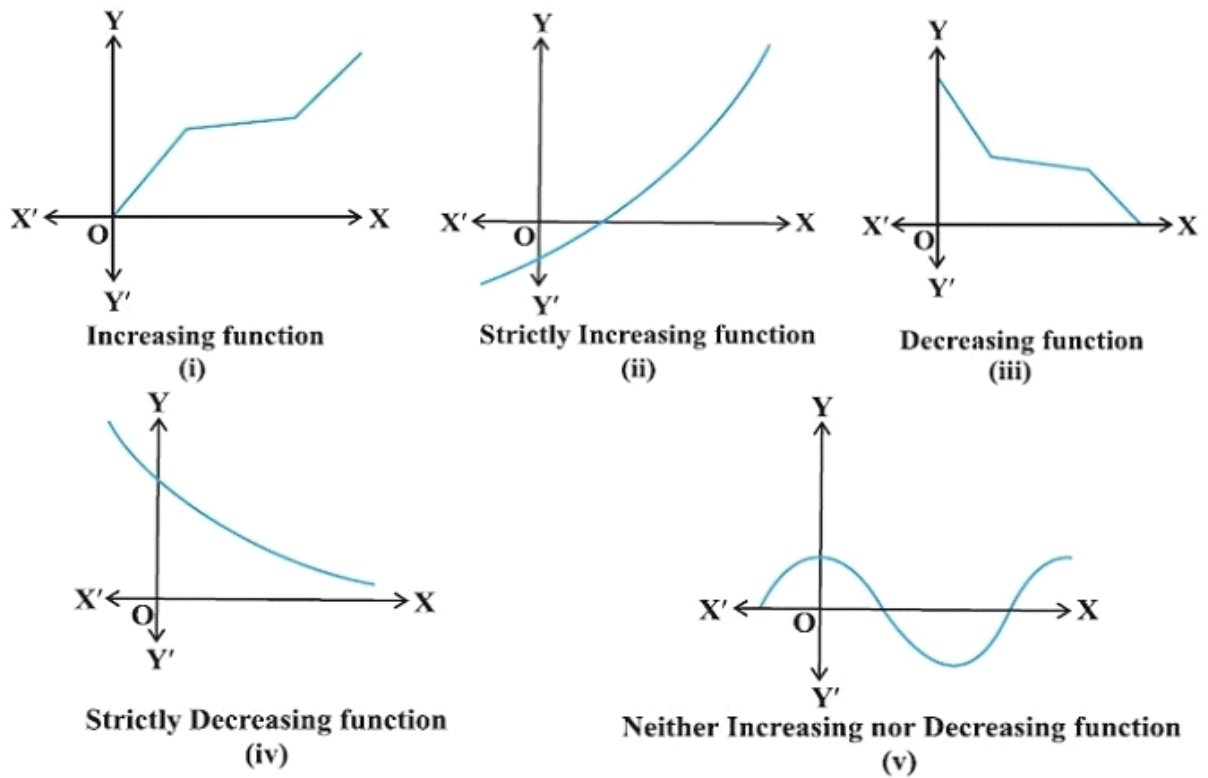

Note: If for a given interval $I \subseteq \mathbb{R}$, function f increase for some values in I and decrease for other values in I , then we say function is neither increasing nor decreasing.

Let x_0 be a point in the domain of definition of a real-valued function f , then f is said to be increasing, strictly increasing, decreasing or strictly decreasing at x_0 , if there exists an open interval I containing x_0 such that f is increasing, strictly increasing, decreasing or strictly decreasing, respectively in I .

Note: If for a given interval $I \subseteq \mathbb{R}$, function f increase for some values in I and decrease for other values in I , then we say function is neither increasing nor decreasing.

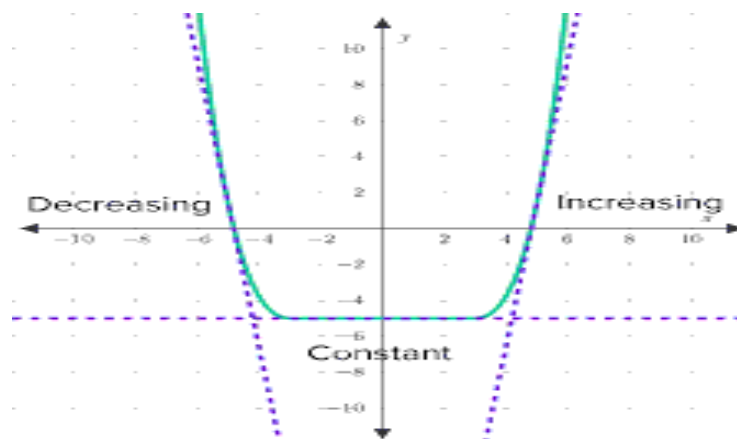

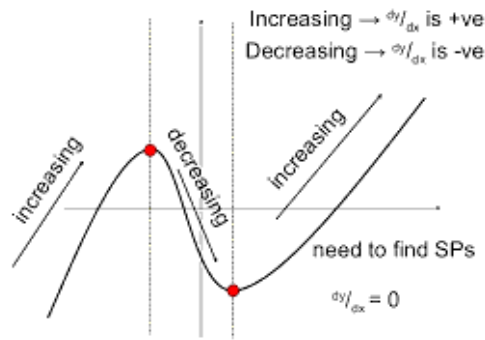

• **MAXIMA AND MINIMA**

Let f be continuous on $[a, b]$ and differentiable on the open interval (a, b) . Then,

Maximum and Minimum Value: Let f be a function defined on an interval I . Then,

- f is said to have a maximum value in I , if there exists a point c in I such that $f(c) > f(x), \forall x \in I$. The number $f(c)$ is called the maximum value of f in I and the point c is called a point of a maximum value of f in I .
- (ii) f is said to have a minimum value in I , if there exists a point c in I such that $f(c) < f(x), \forall x \in I$. The number $f(c)$ is called the minimum value of f in I and the point c is called a point of minimum value of f in I .
- (iii) f is said to have an extreme value in I , if there exists a point c in I such that $f(c)$ is either a maximum value or a minimum value of f in I . The number $f(c)$ is called an extreme value off in I and the point c is called an extreme point.

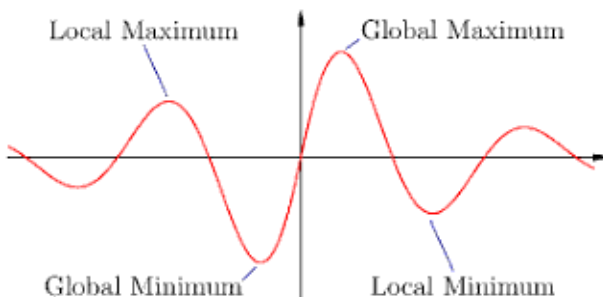
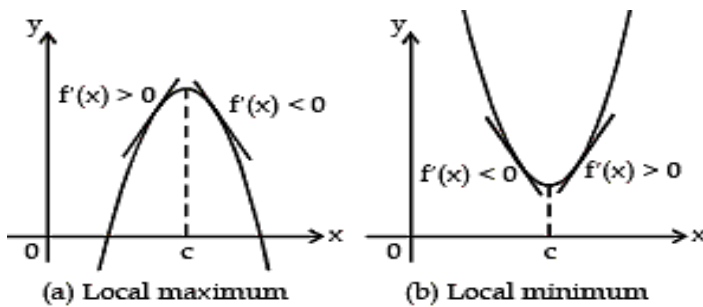

Local Maxima and Local Minima

- (i) A function $f(x)$ is said to have a local maximum value at point $x = a$, if there exists a neighbourhood $(a - \delta, a + \delta)$ of a such that $f(x) < f(a), \forall x \in (a - \delta, a + \delta), x \neq a$. Here, $f(a)$ is called the local maximum value of $f(x)$ at the point $x = a$. (ii) A function $f(x)$ is said to have a local

minimum value at point $x = a$, if there exists a neighbourhood $(a - \delta, a + \delta)$ of a such that $f(x) > f(a)$, $\forall x \in (a - \delta, a + \delta)$, $x \neq a$. Here, $f(a)$ is called the local minimum value of $f(x)$ at $x = a$.

The points at which a function changes its nature from decreasing to increasing or vice-versa are called turning points.

Note:

(i) Through the graphs, we can even find the maximum/minimum value of a function at a point at which it is not even differentiable.

(ii) Every monotonic function assumes its maximum/minimum value at the endpoints of the domain of definition of the function.

Every continuous function on a closed interval has a maximum and a minimum value.

Let f be a function defined on an open interval I . Suppose $c \in I$ is any point. If f has local maxima or local minima at $x = c$, then either $f'(c) = 0$ or f is not differentiable at c .

Critical Point: A point c in the domain of a function f at which either $f'(c) = 0$ or f is not differentiable, is called a critical point of f .

First Derivative Test: Let f be a function defined on an open interval I and f be continuous of a critical point c in I . Then,

- if $f'(x)$ changes sign from positive to negative as x increases through c , then c is a point of local maxima.
- if $f'(x)$ changes sign from negative to positive as x increases through c , then c is a point of local minima.
- if $f'(x)$ does not change sign as x increases through c , then c is neither a point of local maxima nor a point of local minima. Such a point is called a point of inflection.

Second Derivative Test: Let $f(x)$ be a function defined on an interval I and $c \in I$. Let f be twice differentiable at c . Then,

(i) $x = c$ is a point of local maxima, if $f'(c) = 0$ and $f''(c) < 0$. (ii) $x = c$ is a point of local minima, if $f'(c) = 0$ and $f''(c) > 0$.

(iii) the test fails, if $f'(c) = 0$ and $f''(c) = 0$.

Note

(i) If the test fails, then we go back to the first derivative test and find whether a is a point of local maxima, local minima or a point of inflexion.

(ii) If we say that f is twice differentiable at a , then it means second order derivative exists at a .

Absolute Maximum Value: Let $f(x)$ be a function defined in its domain say $Z \subset \mathbb{R}$. Then, $f(x)$ is said to have the maximum value at a point $a \in Z$, if $f(x) \leq f(a)$, $\forall x \in Z$.

Absolute Minimum Value: Let $f(x)$ be a function defined in its domain say $Z \subset \mathbb{R}$. Then, $f(x)$ is said to have the minimum value at a point $a \in Z$, if $f(x) \geq f(a)$, $\forall x \in Z$.

Note: Every continuous function defined in a closed interval has a maximum or a minimum value which lies either at the end points or at the solution of $f'(x) = 0$ or at the point, where the function is not differentiable.

Let f be a continuous function on an interval $I = [a, b]$. Then, f has the absolute maximum value and attains it at least once in I . Also, f has the absolute minimum value and attains it at least once in I .

Quadratic Functions - Min/Max

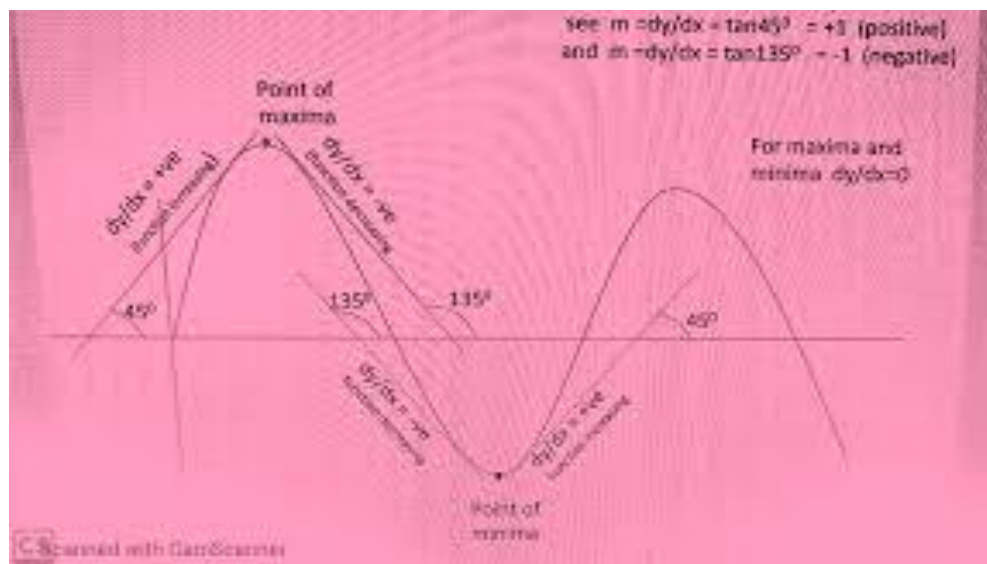
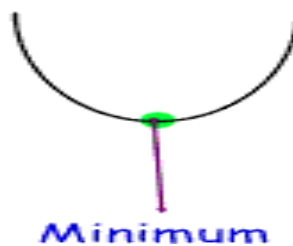
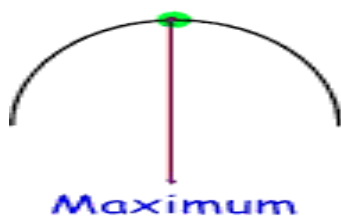

Very Short Answer Questions - 2 Mark Questions

1. The total cost associated with the product of units of an item is given by . Find the marginal cost when 3 units are produced, where the marginal cost we mean the instantaneous rate of change of total cost at any level of output.
2. The volume of a cube is increasing at the rate of $9 \text{ cm}^3/\text{s}$. How fast is its surface area is increasing when the length of an edge is 10 cm.?
3. The volume of a sphere is increasing at the rate of $8 \text{ cm}^3/\text{s}$. Find the rate at which its surface area is increasing when the radius of the sphere is 12 cm.
4. Prove that the function is increasing on \mathbb{R} .

5 The length of a rectangle is decreasing at the rate of 5 cm minute and the width is increasing at the rate of 4 cm minute , when $l = 8$ cm and $w = 6$ cm, find the rate of change of the (a) perimeter and (b) the area of rectangle.

- 3 Mark Questions

6 The two equal sides of an isosceles triangle with fixed base b are decreasing at the rate of 3 cm/sec. How fast is the area decreasing when the two equal sides are equal to the base?

7. Find the intervals in which the function f is

(a) strictly increasing (b) strictly decreasing.

8. Find the intervals in which the function f , given by f

Is (i) strictly increasing (ii) strictly decreasing.

9. Show that the function given by f is always an strictly increasing function in I .

10. Find the points of local maxima, local minima and the points of inflection of the function f . Also, find the corresponding local maximum and local minimum values. Ans: local maxim at $x = a$; local minima at $x = b$,Point of inflection at $x = c$

11. Find the intervals in which the function f is

(a) strictly increasing (b) strictly decreasing.

SECTION C- 5 Mark Questions

12. A wire of length 28 cm is to be cut into two pieces. One of the two pieces is to be made into a square and other into a circle .What should be the lengths of two pieces so that the combined area of the circle and the square is minimum
Ans:

13. A farmer wants to construct a circular garden and a square garden in his field. He wants to keep the sum of their perimeters 600 m. Prove that the sum of their areas is the least, when the side of the square garden is double the radius of the circular garden. Do you think that a good planning can save energy, time and money? Ans:

14 An open tank with a square base and vertical sides is to be constructed from a metal sheet so as to hold a given quantity of water. Show that the cost of material will be least when depth of the tank is half of its width. If the cost is to be borne by nearby settled lower income families, for whom water will be provided, what kind of value is hidden in this question ?

15. Find the points of local maxima, local minima and the points of inflection of the function f . Also, find the corresponding local maximum and local minimum values. Ans: local maxim at $x = a$; local minima at $x = b$,Point of inflection at $x = c$

16. Show that height of the cylinder of greatest volume which can be inscribed in a right circular cone of height h and semi-vertical angle is one-third that of the cone and the greatest volume of the cylinder is .

17. Show that the semi-vertical angle of a right circular cone of maximum volume and of given slant height is .

18. An open box, with a square base is to be made out of a given quantity of metal sheet of area c^2 . Show that the maximum volume of the box is .

19. A magazine seller has 500 subscribers and collects annual subscription charges of Rs 300 per subscriber. She proposes to increase the annual subscription charges and it is believed that for every increase of Re 1, one subscriber will discontinue. What increase will bring maximum income to her? Make appropriate assumptions in order to apply derivatives to reach the solution. Write one important role of magazines in our lives .Ans:

20. A window is in the form of a rectangle surmounted by a semi-circular opening. The total perimeter of the window is 10 m. Find the dimensions of the window to admit maximum light through the whole opening.Ans:

CASE STUDY PROBLEM-1

Following is the pictorial description for a page. The total area of the page is 150 cm^2 . The combined width of the margin at the top and bottom is 3 cm and the side 2 cm.



Using the information given above, answer the following :

(i) The relation between x and y is given by

ANS ($x - 2$)($y - 3$) = 150

(ii) The area of page where printing can be done, is given by

ANS: $(x - 3)(y - 2)$

(iii) The area of the printable region of the page, in terms of x , is

OR

For what value of ' x ', the printable area of the page is maximum?

CASE STUDY PROBLEM-2

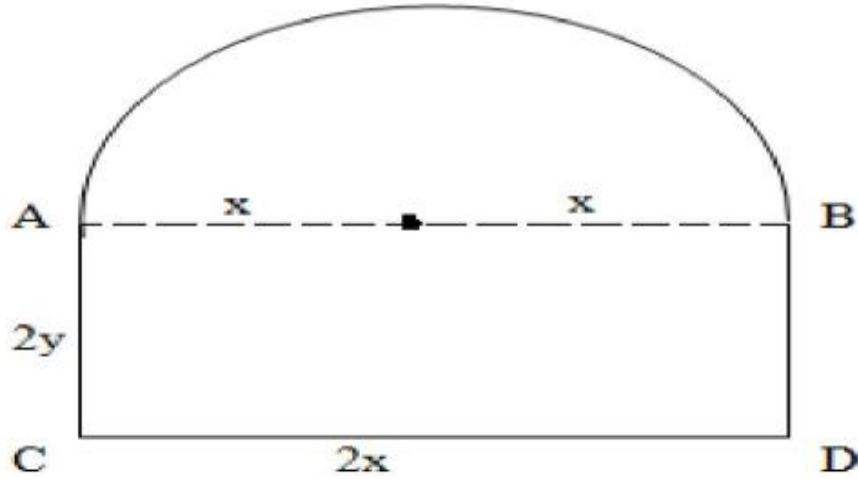

Mr Shashi, who is an architect, designs a building for a small company. The design of window on the ground floor is proposed to be different than other floors. The window is in the shape of a rectangle which is surmounted by a semi-circular opening. This window is having a perimeter of 10 m as shown below :

Based on the above information answer the following :

(i) If $2x$ and $2y$ represents the length and breadth of the rectangular portion of the windows, then the relation between the variables is:

ANS- $4y=10-(2+\pi) x$

(ii) The combined area (A) of the rectangular region and semi-circular region of the window expressed as a function of x is:

ANS- $A = 10x-(2+12\pi) x^2$

(iii) The maximum value of area A, of the whole window is

ANS : $50/4+ \pi$

OR

(IV) The owner of this small company is interested in maximizing the area of the whole window so that maximum light input is possible.

For this to happen, the length of rectangular portion of the window should be

ANS: $20/4+ \pi$

CASE STUDY PROBLEM-3

An architect designs a building for a multi-national company. The floor consists of a rectangular region with semicircular ends having a perimeter of 200m as shown below:

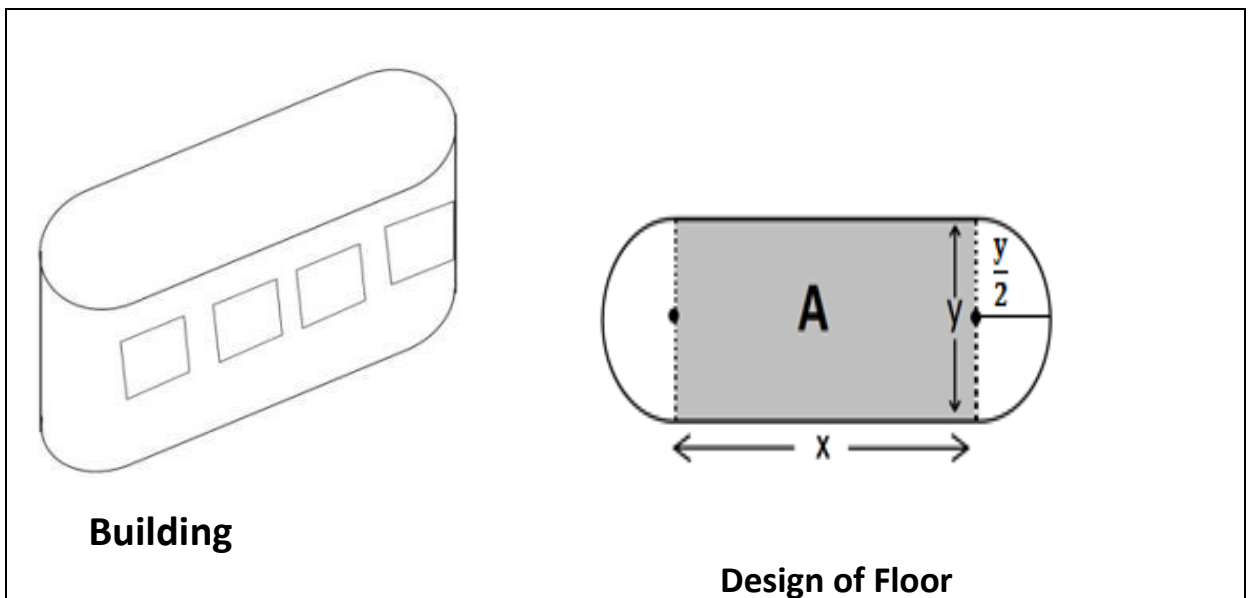

Based on the above information answer the following:

(i) If x and y represents the length and breadth of the rectangular region, then the relation between the variables is

(ii) The area of the rectangular region expressed as a function of x is

(iii) The maximum value of area A is
OR

(iv) The CEO of the multi-national company is interested in maximizing the area of the whole floor including the semi-circular ends. For this to happen the value of x should be

CASE STUDY PROBLEM-4

4. A telephone company in a town has 500 subscribers on its list and collects fixed charges of 300 per subscriber per year. The company proposes to increase the annual subscription and it is believed that for every increase of 1 one subscriber will discontinue the service.

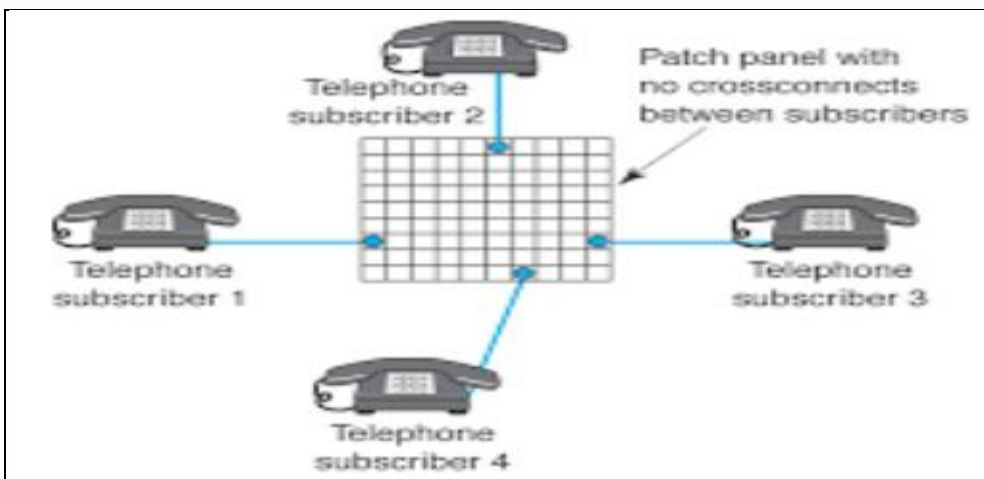

1. If x be the annual subscription then the total revenue of the company after increment will be:
2. How much fee the company should increase to have maximum profit?
3. Find the maximum profit that the company can make if the profit function is given by $P(x) = 41 + 24x - 18x^2$.

OR

4. Find both the maximum and minimum values respectively of $3x^4 - 8x^3 + 48x + 1$ on the interval $[1, 4]$.

Answer Key:

1. $-x^2 + 200x + 150000$
 2. Rs.100
 3. 49
- OR
4. 257, -63

TOPIC-APPLICATION OF DERIVATIVES

1. Assertion(A): Function $f(x) = x^3 - 3x^2 + 3x + 2$ is always increasing.
Reason(R): Derivative $f'(x)$ is always negative.
A. Both A and R are true and R is the correct explanation of A
B. Both A and R are true but R is the correct explanation of A
C. A is true but R is false

D. A is false but R is true

2. Assertion(A): $y = e^x$ is always strictly increasing function.

Reason (R): $dy/dx = e^x > 0$ for all real values of x .

- A. Both A and R are true and R is the correct explanation of A
- B. Both A and R are true but R is the correct explanation of A
- C. A is true but R is false
- D. A is false but R is true

3. Assertion(A): Function $f(x) = x + 1/x$ is strictly increasing in the interval $(-1, 1)$

Reason(R) : Derivative $f'(x) < 0$ in the interval

- A. Both A and R are true and R is the correct explanation of A
- B. Both A and R are true but R is the correct explanation of A
- C. A is true but R is false
- D. A is false but R is true

4. Assertion (A): $x = 0$ is the point of local maxima of the function f given by

$$f = 3x^4 + 4x^3 - 12x^2 + 12$$

Reason(R): $f(x) = 0$ at $x = 0$ and also $f'(x) < 0$ at $x = 0$

- A. Both A and R are true and R is the correct explanation of A
- B. Both A and R are true but R is the correct explanation of A

C. A is true but R is false

D. A is false but R is true

5.. Assertion (A): Maximum value of the function $f(x) = (2x - 1)^2 + 3$ is 3.

Reason(R): $f(x) \geq 3$ for all real values of x .

A. Both A and R are true and R is the correct explanation of A

B. Both A and R are true but R is the correct explanation of A

C. A is true but R is false

D. A is false but R is true

6. .Assertion $f(x) = e^x$ do not have maxima and minima

Reason (R) : $f'(x) = e^x \neq 0$ for all real values of x .

A. Both A and R are true and R is the correct explanation of A

B. Both A and R are true but R is the correct explanation of A

C. A is true but R is false

D. A is false but R is true

MCQ - APPLICATION OF DERIVATIVES

1. The side of an equilateral triangle is increasing at the rate of 2 cm/s. The rate at which area increases when the side is 10 is

(A) 10 cm²/s (B) $\frac{10}{3}$ cm²/s (C) $\sqrt{3}$ cm²/s (D) $10\sqrt{3}$ cm²/s

Answer: (D) $10\sqrt{3}$ cm²/s

2. If there is an error of 2% in measuring the length of a simple pendulum, then percentage error in its period is

(A) 1% (B) 2% (C) 3% (D) 4%

Answer: (A) 1%

3. The absolute maximum value of $y = x^3 - 3x + 2$ in $0 \leq x \leq 2$ is

- a. 0
- b. 2
- c. 4
- d. 6

Answer: (c) 4

4. The function $f(x) = x + \cos x$ is

- a. Always increasing
- b. Always decreasing
- c. Increasing for a certain range of x
- d. None of these

Answer: (a) Always increasing

5, Let the $f: \mathbb{R} \rightarrow \mathbb{R}$ be defined by $f(x) = 2x + \cos x$, then f

- a. has a maximum, at $x = 0$
- b. has a minimum at $x = 3\pi$
- c. is an increasing function
- d. is a decreasing function

Answer: (c) is an increasing function

6. The point(s) on the curve $y = x^2$, at which y -coordinate is changing six times as fast as x -coordinate is/are

- a. (6, 2)
- b. (2, 4)
- c. (3, 9)
- d. (3, 9), (9, 3)

Answer: (c) (3, 9)

7. If $y = x^3 + x^2 + x + 1$, then y

- a. has a local minimum
- b. has a local maximum
- c. neither has a local minimum nor local maximum
- d. None of the above

Answer: (c) neither has a local minimum nor local maximum

8. A ladder, 5 meter long, standing on a horizontal floor, leans against a vertical wall. If the top of the ladder slides downwards at the rate of 10 cm/sec, then the rate at which the angle between the floor and the ladder is decreasing when lower end of ladder is 2 metres from the wall is

- (a) $1/10$ radian/sec
- (b) $1/20$ radian/sec
- (c) 20 radian/sec
- (d) 10 radian/sec

Ans; (b) $1/20$ radian/sec

9. If $y = x^4 - 10$ and if x changes from 2 to 1.99 what is the change in y

- (a) 0.32
- (b) 0.032
- (c) 5.68
- (d) 5.968

Ans: (a) 0.32

10. The interval on which the function $f(x) = 2x^3 + 9x^2 + 12x - 1$ is decreasing is

- (a) $[-1, \infty]$
- (b) $[-2, -1]$
- (c) $[-\infty, -2]$
- (d) $[-1, 1]$.

Ans: (b) $[-2, -1]$

CHAPTER 7 :INTEGRALS

Basic Concepts:

1. **Antiderivative (or Primitive)** : A function $\phi(x)$ is said to be antiderivative or primitive of a function $f(x)$ if $\phi'(x) = f(x)$.

For example : $\sin x$ is one of the antiderivative or primitive of $\cos x$, because

$$\begin{aligned} \frac{d}{dx}(\sin x) &= \cos x \\ \frac{d}{dx}(\sin x + 1) &= \cos x \\ \frac{d}{dx}(\sin x + 2) &= \cos x \\ \frac{d}{dx}(\sin x + 3) &= \cos x \\ &\dots\dots\dots \\ &\dots\dots\dots \\ \frac{d}{dx}(\sin x + C) &= \cos x \end{aligned}$$

We conclude that a function has infinitely many antiderivatives.

That is $\phi(x)$ be an antiderivative of $f(x)$, then $\phi(x) + C$ is also antiderivative of $f(x)$, where C is any constant.

2. **Indefinite Integrals** : If $f(x)$ is a function then the family of all its antiderivatives is called Indefinite Integral of $f(x)$. It is represented by:

$$\int f(x)dx \quad (\text{read as indefinite integral of } f(x) \text{ with respect to } x)$$

Derivatives	Integrals
$\frac{d}{dx} \left(\frac{x^{n+1}}{n+1} \right) = x^n ;$	$\int x^n dx = \frac{x^{n+1}}{n+1} + C, n \neq -1$
Particularly, we note that	
$\frac{d}{dx}(x) = 1 ;$	$\int dx = x + C$
$\frac{d}{dx}(\sin x) = \cos x ;$	$\int \cos x dx = \sin x + C$
$\frac{d}{dx}(-\cos x) = \sin x ;$	$\int \sin x dx = -\cos x + C$
$\frac{d}{dx}(\tan x) = \sec^2 x ;$	$\int \sec^2 x dx = \tan x + C$
$\frac{d}{dx}(-\cot x) = \operatorname{cosec}^2 x ;$	$\int \operatorname{cosec}^2 x dx = -\cot x + C$
$\frac{d}{dx}(\sec x) = \sec x \tan x ;$	$\int \sec x \tan x dx = \sec x + C$
$\frac{d}{dx}(-\operatorname{cosec} x) = \operatorname{cosec} x \cot x ;$	$\int \operatorname{cosec} x \cot x dx = -\operatorname{cosec} x + C$

Derivatives

Integrals

$$\frac{d}{dx} (\sin^{-1} x) = \frac{1}{\sqrt{1-x^2}} ;$$

$$\int \frac{dx}{\sqrt{1-x^2}} = \sin^{-1} x + C$$

$$\frac{d}{dx} (-\cos^{-1} x) = \frac{1}{\sqrt{1-x^2}} ;$$

$$\int \frac{dx}{\sqrt{1-x^2}} = -\cos^{-1} x + C$$

$$\frac{d}{dx} (\tan^{-1} x) = \frac{1}{1+x^2} ;$$

$$\int \frac{dx}{1+x^2} = \tan^{-1} x + C$$

$$\frac{d}{dx} (e^x) = e^x ;$$

$$\int e^x dx = e^x + C$$

$$\frac{d}{dx} (\log |x|) = \frac{1}{x} ;$$

$$\int \frac{1}{x} dx = \log |x| + C$$

$$\frac{d}{dx} \left(\frac{a^x}{\log a} \right) = a^x ;$$

$$\int a^x dx = \frac{a^x}{\log a} + C$$

3. Methods of Integration:

- (i) Integration by substitution
- (ii) Integration by Partial Fractions.
- (iii) Integration by Parts

Integration by substitution : The given integral $\int f(x) dx$ can be transformed into another form by Changing the independent variable x to t by substituting $x = g(t)$.

Consider $I = \int f(x) dx$

Put $x = g(t)$ so that

By differentiating find dx/dt and

We write $dx = g'(t) dt$

This change of variable formula is one of the important tools available to us in the name of integration by substitution. It is often important to guess what will be the useful substitution. Usually, we make a substitution for a function whose derivative also occurs in the integrand.

Integration by Partial Fractions :

A rational function is defined as the ratio of two polynomials in the form $\frac{P(x)}{Q(x)}$, where $P(x)$ and $Q(x)$ are polynomials in x and $Q(x) \neq 0$. If the degree of $P(x)$ is less than the degree of $Q(x)$, then the rational function is called proper, otherwise, it is called improper. The improper rational functions can be reduced to the proper rational functions by long division process.

S.No.	Form of the rational function	Form of the partial fraction
1.	$\frac{px+q}{(x-a)(x-b)}, a \neq b$	$\frac{A}{x-a} + \frac{B}{x-b}$
2.	$\frac{px+q}{(x-a)^2}$	$\frac{A}{x-a} + \frac{B}{(x-a)^2}$
3.	$\frac{px^2+qx+r}{(x-a)(x-b)(x-c)}$	$\frac{A}{x-a} + \frac{B}{x-b} + \frac{C}{x-c}$
4.	$\frac{px^2+qx+r}{(x-a)^2(x-b)}$	$\frac{A}{x-a} + \frac{B}{(x-a)^2} + \frac{C}{x-b}$
5.	$\frac{px^2+qx+r}{(x-a)(x^2+bx+c)}$	$\frac{A}{x-a} + \frac{Bx+C}{x^2+bx+c}$

where $x^2 + bx + c$ cannot be factorised further

In the above table, A, B and C are real numbers to be determined suitably.

Integration by Parts :

If u and v are any two differentiable functions of a single variable x . Then,

$$\int u \cdot v \, dx = u \int v \, dx - \int \left[\frac{du}{dx} \cdot \int v \, dx \right] dx$$

“The integral of the product of two functions = (first function) \times (integral of the second function) – Integral of [(differential coefficient of the first function) \times (integral of the second function)]”

(i) To integrate the product of two functions we choose the first function according to the word **ILATE** where **I** stands for inverse function

L stands for logarithmic function

A stands for algebraic function

T stands for trigonometric function and

E stands for exponential function

(ii) If integrand has only one function then 1 is taken to be the second function.

4. Integrals of Some Particular Functions:

$$1. \int \frac{dx}{a^2+x^2} = \frac{1}{a} \tan^{-1} \frac{x}{a} + C$$

$$4. \int \frac{1}{\sqrt{a^2+x^2}} = \log|x + \sqrt{a^2 + x^2}| + C$$

$$2. \int \frac{dx}{x^2-a^2} = \frac{1}{2a} \log \left| \frac{x-a}{x+a} \right| + C$$

$$5. \int \frac{1}{\sqrt{x^2-a^2}} = \log|x + \sqrt{x^2 + a^2}| + C$$

$$3. \int \frac{dx}{a^2-x^2} = \frac{1}{2a} \log \left| \frac{a+x}{a-x} \right| + C$$

$$6. \int \frac{1}{\sqrt{a^2-x^2}} = \sin^{-1} \frac{x}{a} + C$$

5. Integrals of the type:

(i) $\int \frac{1}{ax^2+bx+c} dx$ Apply completing square method for $ax^2 + bx + c$ and use suitable formulae from above.

(ii) $\int \frac{1}{\sqrt{ax^2+bx+c}} dx$ Apply completing square method for $ax^2 + bx + c$ and use suitable formulae from above.

(iii) $\int \frac{px+q}{ax^2+bx+c} dx$ and $\int \frac{px+q}{\sqrt{ax^2+bx+c}} dx$

$$\text{Write } px + q = A \left(\frac{d}{dx} \{ax^2 + bx + c\} \right) + B$$

$$px + q = A(2ax + b) + B$$

Find A and B by equating coefficients of like powers of x from both sides

Then express the given integrals as the sum of two integrals and apply substitution method in first part and in the second part completing square method for $ax^2 + bx + c$ and use suitable formulae from above.

6. Integrals of some more type:

(For the following integrals consider 1 as second function and evaluate)

(i) $\int \sqrt{x^2 - a^2} dx = \frac{x}{2} \sqrt{x^2 - a^2} - \frac{a^2}{2} \log|x + \sqrt{x^2 - a^2}| + C$

(ii) $\int \sqrt{x^2 + a^2} dx = \frac{x}{2} \sqrt{x^2 + a^2} + \frac{a^2}{2} \log|x + \sqrt{x^2 + a^2}| + C$

(iii) $\int \sqrt{a^2 - x^2} dx = \frac{x}{2} \sqrt{a^2 - x^2} + \frac{a^2}{2} \sin^{-1} \frac{x}{a} + C$

7. Integrals of the type: $\int e^x [f(x) + f'(x)] dx = e^x f(x) + C$

Definite Integral

The definite integral has a unique value. A definite integral is denoted by $\int_a^b f(x) dx$ where a is called the lower limit of the integral and b is called the upper limit of the integral. The definite integral is introduced either as the limit of a sum or if it has an anti derivative F in the interval $[a, b]$, then its value is the difference between the values of F at the end points, i.e., $F(b) - F(a)$.

7.8 Fundamental Theorem of Calculus

7.8.1 Area function

We have defined $\int_a^b f(x) dx$ as the area of the region bounded by the curve $y = f(x)$, the ordinates $x = a$ and $x = b$ and x -axis. Let x

be a given point in $[a, b]$. Then $\int_a^x f(x) dx$ represents the area of the shaded region

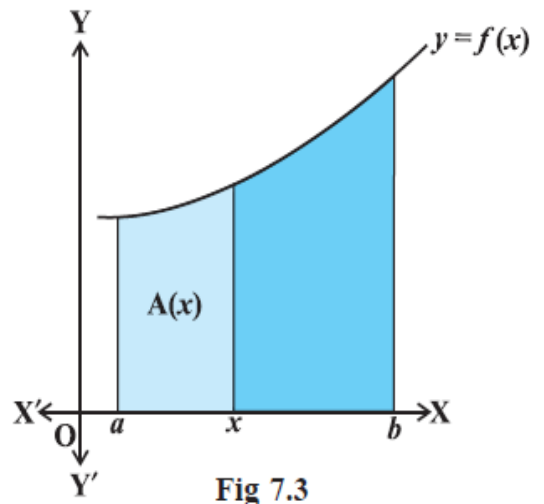

The area of this shaded region is a function of x . We denote this function of x by $A(x)$.

We call

the function $A(x)$ as *Area function* and is given by

$$A(x) = \int_a^x f(x) dx$$

$$A(x) = F(b) - F(a).$$

Properties of definite Integrals

$$P_0 : \int_a^b f(x) dx = \int_a^b f(t) dt$$

$$P_1 : \int_a^b f(x) dx = -\int_b^a f(x) dx. \text{ In particular, } \int_a^a f(x) dx = 0$$

$$P_2 : \int_a^b f(x) dx = \int_a^c f(x) dx + \int_c^b f(x) dx$$

$$P_3 : \int_a^b f(x) dx = \int_a^b f(a+b-x) dx$$

$$P_4 : \int_0^a f(x) dx = \int_0^a f(a-x) dx$$

(Note that P_4 is a particular case of P_3)

$$P_5 : \int_0^{2a} f(x) dx = \int_0^a f(x) dx + \int_0^a f(2a-x) dx$$

$$P_6 : \int_0^{2a} f(x) dx = 2 \int_0^a f(x) dx, \text{ if } f(2a-x) = f(x) \text{ and} \\ 0 \text{ if } f(2a-x) = -f(x)$$

$$P_7 : \text{ (i) } \int_{-a}^a f(x) dx = 2 \int_0^a f(x) dx, \text{ if } f \text{ is an even function, i.e., if } f(-x) = f(x).$$

$$\text{ (ii) } \int_{-a}^a f(x) dx = 0, \text{ if } f \text{ is an odd function, i.e., if } f(-x) = -f(x).$$

Integration of trigonometric function

Working Rule (a) Express the given integrand as the algebraic sum of the functions of the following forms

(i) $\sin k\alpha$, (ii) $\cos k\alpha$, (iii) $\tan k\alpha$, (iv) $\cot k\alpha$, (v) $\sec k\alpha$, (vi) $\operatorname{cosec} k\alpha$, (vii) $\sec^2 k\alpha$,

(viii) $\operatorname{cosec}^2 k\alpha$, (ix) $\sec k\alpha \tan k\alpha$ (x) $\operatorname{cosec} k\alpha \cot k\alpha$

For this use the following formulae whichever applicable

$$\text{(i) } \sin^2 x = \frac{1 - \cos 2x}{2}$$

$$\text{(ii) } \cos^2 x = \frac{1 + \cos 2x}{2}$$

$$\text{(iii) } \sin^3 x = \frac{3 \sin x - \sin 3x}{4}$$

$$\text{(iv) } \cos^3 x = \frac{3 \cos x + \cos 3x}{4}$$

$$\text{(v) } \tan^2 x = \sec^2 x - 1$$

$$\text{(vi) } \cot^2 x = \operatorname{cosec}^2 x - 1$$

$$\text{(vii) } 2 \sin x \sin y = \cos(x-y) - \cos(x+y)$$

$$\text{(vii) } 2 \cos x \cos y = \cos(x+y) + \cos(x-y)$$

$$\text{(ix) } 2 \sin x \cos y = \sin(x+y) + \sin(x-y)$$

$$\text{(x) } 2 \cos x \sin y = \sin(x+y) - \sin(x-y)$$

SOLVED PROBLEMS

Evaluate the following integrals

$$1. \int \frac{(1 + \log X)^2}{X} dx$$

Solution: put $1 + \log x = t$

$$\frac{1}{x} dx = dt$$

$$\int \frac{(1 + \log X)^2}{X} dx = \int t^2 dt$$

$$= \frac{t^3}{3} + c$$

$$= \frac{(1+\log x)^3}{3} + c$$

2. $\int \frac{e^x}{\sqrt{5-4e^x-e^{2x}}} dx$

Solution: Put $e^x = t$ then $e^x dx = dt$

$$\int \frac{e^x}{\sqrt{5-4e^x-e^{2x}}} dx = \int \frac{dt}{\sqrt{5-4t-t^2}}$$

$$= \int \frac{dt}{\sqrt{-(t^2+4t-5)}}$$

$$= \int \frac{dt}{\sqrt{-(t^2+4t+4-4-5)}}$$

$$= \int \frac{dt}{\sqrt{-\{(t+2)^2-9\}}}$$

$$= \int \frac{dt}{\sqrt{3^2-(t+2)^2}}$$

$$= \sin^{-1} \frac{t+2}{3} + C = \sin^{-1} \left(\frac{e^x+2}{3} \right) + C$$

3. $\int \sqrt{\tan x} dx$

Solution : Put $\tan x = t^2$ then $\sec^2 x dx = 2t dt \Rightarrow dx = \frac{2t dt}{1+t^4}$

$$\int \sqrt{\tan x} dx = \int t \frac{2t dt}{1+t^4} = \int \frac{2t^2}{1+t^4} dt$$

$$= \int \frac{2}{\frac{1}{t^2} + t^2} dt \quad (\text{by dividing nr and dr by } t^2)$$

$$= \int \frac{\left(1 + \frac{1}{t^2}\right) + \left(1 - \frac{1}{t^2}\right)}{t^2 + \frac{1}{t^2}} dt$$

$$= \int \frac{1 + \frac{1}{t^2}}{t^2 + \frac{1}{t^2}} dt + \int \frac{1 - \frac{1}{t^2}}{t^2 + \frac{1}{t^2}} dt$$

$$= \int \frac{1 + \frac{1}{t^2}}{\left(t - \frac{1}{t}\right)^2 + 2} dt + \int \frac{1 - \frac{1}{t^2}}{\left(t + \frac{1}{t}\right)^2 - 2} dt$$

$$= \int \frac{du}{u^2+2} + \int \frac{dv}{v^2-2} \quad (1^{\text{st}} \text{ integral put } t - \frac{1}{t} = u \quad \text{then } \left(1 + \frac{1}{t^2}\right) dt = du$$

2nd integral put $t + \frac{1}{t} = v$ then $\left(1 - \frac{1}{t^2}\right) dt = dv$

$$= \frac{1}{\sqrt{2}} \tan^{-1} \left(\frac{u}{\sqrt{2}} \right) + \frac{1}{2\sqrt{2}} \log \left| \frac{v-\sqrt{2}}{v+\sqrt{2}} \right| + C$$

$$= \frac{1}{\sqrt{2}} \tan^{-1} \left(\frac{t-\frac{1}{t}}{\sqrt{2}} \right) + \frac{1}{2\sqrt{2}} \log \left| \frac{t+\frac{1}{t}-\sqrt{2}}{t+\frac{1}{t}+\sqrt{2}} \right| + C$$

$$= \frac{1}{\sqrt{2}} \tan^{-1} \left(\frac{t^2-1}{\sqrt{2}t} \right) + \frac{1}{2\sqrt{2}} \log \left| \frac{t^2+1-\sqrt{2}t}{t^2+1+\sqrt{2}t} \right| + C$$

$$= \frac{1}{\sqrt{2}} \tan^{-1} \left(\frac{\tan x-1}{\sqrt{2} \tan x} \right) + \frac{1}{2\sqrt{2}} \log \left| \frac{\tan x+1-\sqrt{2}\tan x}{\tan x+1-\sqrt{2}\tan x} \right| + C$$

4. $\int \frac{5x+3}{\sqrt{x^2+4x+10}} dx$

Solution: $5x+3 = A(2x+4) + B \Rightarrow A = \frac{5}{2}$ and $B = -7$

$$\int \frac{5x+3}{\sqrt{x^2+4x+10}} dx = \int \frac{\frac{5}{2}(2x+4) - 7}{\sqrt{x^2+4x+10}} dx$$

$$= \int \frac{\frac{5}{2}(2x+4)}{\sqrt{x^2+4x+10}} dx + \int \frac{-7}{\sqrt{x^2+4x+10}} dx$$

$$= \frac{5}{2} \int \frac{(2x+4)}{\sqrt{x^2+4x+10}} dx + 7 \int \frac{1}{\sqrt{x^2+4x+10}} dx$$

$$= \frac{5}{2} \int \frac{dt}{\sqrt{t}} + 7 \int \frac{1}{\sqrt{x^2+4x+4-4+10}} dx$$

$$= \frac{5}{2} \times 2\sqrt{t} + 7 \int \frac{1}{\sqrt{(x+2)^2+6}} dx$$

$$= 5\sqrt{x^2+4x+10} + 7 \log |x+2 + \sqrt{x^2+4x+10}| + C$$

Case based questions:

Q 1. Ramesh is elder brother of Suresh. Ramesh wants to help his younger brother Suresh to solve the following problems of integrals. Write the suitable substitution by which Ramesh can help him.

(a) $I = \int \frac{\sec^2(2 \tan^{-1}x)}{1+x^2} dx$

(b) $I = \int \sec x \cdot \log(\sec x + \tan x) dx$

(c). $I = \int \frac{e^x(1+x)}{\sin^2(e^x \cdot x)} dx$

(d) $I = \int \frac{1}{x-\sqrt{x}} dx$

[Ans: a. $2 \tan^{-1}x = t$ b. $\sec x + \tan x = t$ c. $e^x \cdot x = t$ d. $\sqrt{x} = t$]

Q 2. A Mathematics teacher taught an important property of definite integral to the students of class XII:

$$\int_a^b f(x) dx = \int_a^b f(a+b-x) dx, \quad f(x) \text{ is defined on } [a, b]$$

After that he has given some problems based on the above property to the students of his class.

Use the above property and answer the following questions:

(i) $\int_{\frac{\pi}{6}}^{\frac{\pi}{3}} \frac{dx}{1+\sqrt{\cot x}}$

(ii) $\int_1^4 \frac{\sqrt{5-x}}{\sqrt{5-x} + \sqrt{x}} dx$

(iii) $\int_0^{\pi} \frac{x}{1+\sin x} dx$

KENDRIYA VIDYALAYA SANGATHAN, RAIPUR REGION (2022-23)
CLASS XII –MATHEMATICS
CHAPTER 8 : APPLICATION OF INTEGRALS

INTRODUCTION

Area under Simple Curves

(i)

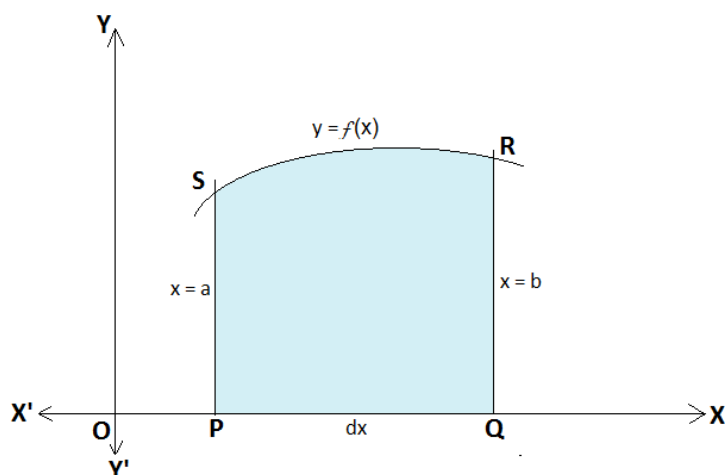

Area bounded by the curve $y = f(x)$, the x-axis and between the ordinates at $x = a$ and $x = b$ is given by

$$\text{Area} = \int_a^b y \, dx = \int_a^b f(x) \, dx$$

(ii)

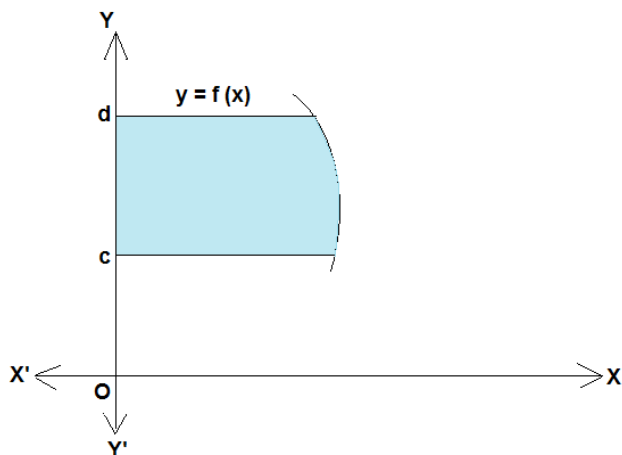

Area bounded by the curve $y = f(x)$, the y axis and between abscissas at $y = c$ and $y = d$ is given by

$$\text{Area} = \int_c^d x \, dx = \int_c^d g(y) \, dy$$

Where $y = f(x) \Rightarrow x = g(y)$

Note: If area lies below x-axis or to left side of y-axis, then it is negative and in such a case we like its absolute value. (numerical value)

WORKING RULE

1. Draw the rough sketch of the given curve
2. Find whether the required area is included between two ordinate or two abscissa
3. (a) If the required area is included between two ordinates $x = a$ and $x = b$ then use the formula $\int_a^b y \, dx$

(b) If the required area is included between two abscissa $y = c$ and $y = d$ then use the

$$\text{Formula } \int_c^d x \, dy$$

SOME IMPORTANT POINTS TO BE KEPT IN MIND FOR SKETCHING THE GRAPH

1. $y^2 = 4ax$ is a parabola with vertex at origin, symmetric to X axis and right of origin
2. $y^2 = -4ax$ is a parabola with vertex at origin, symmetric to X axis and left of origin
3. $x^2 = 4ay$ is a parabola with vertex at origin, symmetric to y axis and above origin
4. $x^2 = -4ay$ is a parabola with vertex at origin, symmetric to y axis and below origin

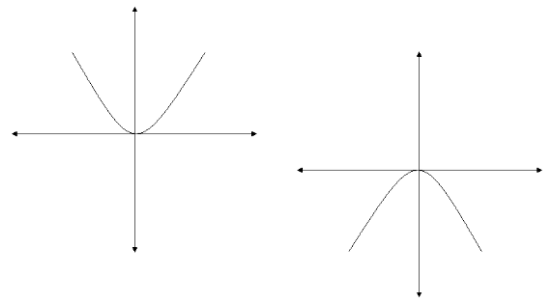
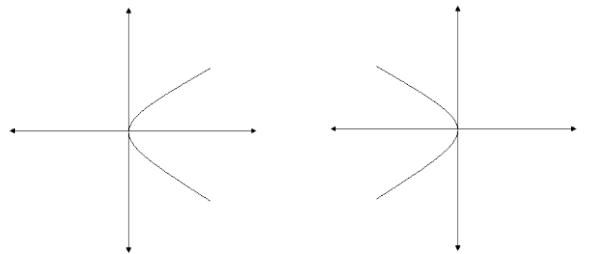

5. $\frac{x^2}{a^2} + \frac{y^2}{b^2} = 1$ is an ellipse symmetric to both axis, Cut x axis at $(\pm a, 0)$ and y axis at $(0, \pm b)$

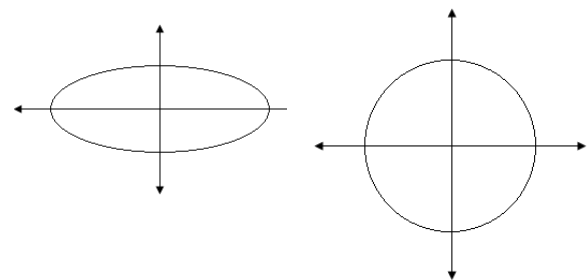

6. $x^2 + y^2 = r^2$ is a circle symmetric to both the axes With centre at origin and radius r
7. $(x - h)^2 + (y - k)^2 = r^2$ is a circle with centre at (h, k) and radius r .
8. $ax + by + c = 0$ representing a straight line

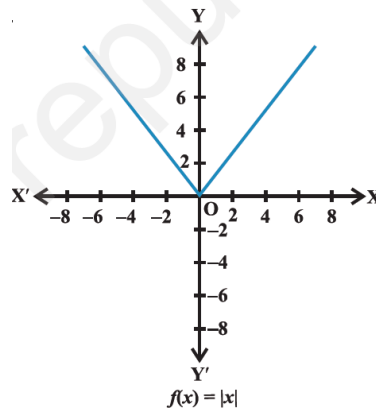

9. Graph of $y = |x|$

SOLVED PROBLEMS

1. Find the area bounded between the lines $y = 2x + 1$, $y = 3x + 1$, $x = 4$ using integration

Solution:

Draw the rough sketch and shaded the area

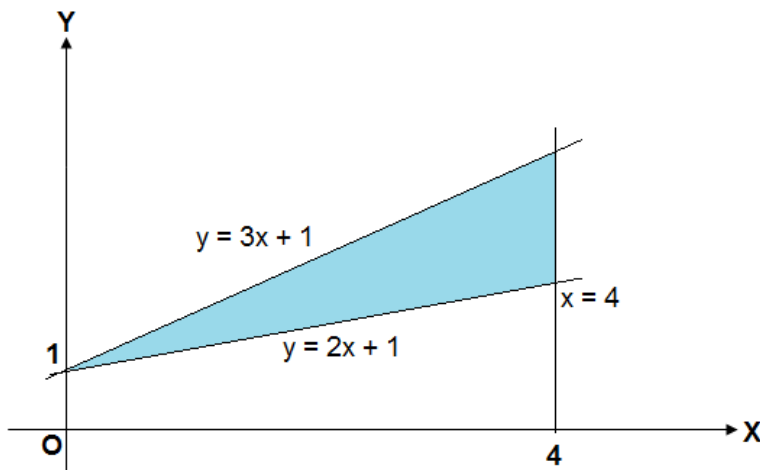

$$\begin{aligned}
 \text{Area enclosed} &= \int_0^4 (f(x) - g(x)) dx \\
 &= \int_0^4 (3x + 1 - 2x - 1) dx \\
 &= \int_0^4 x dx \\
 &= \left[\frac{x^2}{2} \right]_0^4 = 8 \text{ sq. units}
 \end{aligned}$$

2. Find the area enclosed by circle $x^2 + y^2 = a^2$ using integration.

3. Find the area enclosed by the ellipse $\frac{x^2}{25} + \frac{y^2}{16} = 1$ using integration.

ONE MARK QUESTIONS

Multiple Choice Type Questions

Select the Correct Option.

Q1. If $\int f(x)dx = g(x) + C$ then

- (a) $g(x) = f(x)$ (b) $\frac{d}{dx}\{g(x)\} = f(x)$ (c) $\frac{d(f(x))}{dx} = g(x)$ (d) none of these

Q2. $\int \frac{1}{e^x + e^{-x}} dx$

- (a) $\tan^{-1}(e^x) + C$ (b) $\tan^{-1}(e^{-x}) + C$ (c) $\log(e^x + e^{-x}) + C$ (d) $\log(e^x - e^{-x}) + C$

Q3. $\int \frac{\cos\sqrt{x}}{\sqrt{x}} dx$ is equal to:

- (a) $2\cos\sqrt{x}$ (b) $\sqrt{\frac{\cos x}{x}}$ (c) $\sin\sqrt{x}$ (d) $2\sin\sqrt{x}$

Q4. $\int_0^{\frac{\pi}{2}} \sqrt{1 - \sin 2x} dx$ is equal to:

- (a) $2\sqrt{2}$ (b) $2(\sqrt{2} + 1)$ (c) 2 (d) $2(\sqrt{2} - 1)$

Q5. $\int_0^a \frac{\sqrt{x}}{\sqrt{x} + \sqrt{a-x}} dx =$

- (a) a (b) $\frac{a}{2}$ (c) $2a$ (d) 0

Q6. $\int_{-\frac{\pi}{4}}^{\frac{\pi}{4}} \sin^3 x dx$ is equal to:

- (a) 1 (b) $\frac{\pi}{4}$ (c) $\frac{\pi}{2}$ (d) 0

[Answers: 1(b), 2(a), 3(d), 4(d), 5(b), 6(d)]

Answer the following questions: (3marks)

1. $\int \sin^3 x dx$ 2. $\int \sin 3x \cos 5x dx$ 3. $\int \sin^3 x \cos^5 x dx$

4. $\int \frac{dx}{x^2 + 4x + 1}$ 5. $\int \frac{dx}{\sqrt{x^2 + 5x + 8}}$ 6. $\int_0^{\frac{\pi}{4}} \tan^2 x dx$ 7. $\int x^2 e^x dx$

Evaluate the following integrals (3 Marks)

1. $\int \frac{\sin x}{\sin(x-a)} dx$ 2. $\int \frac{2}{(1-x)(1+x^2)} dx$ 3. $\int \frac{x+2}{\sqrt{(x-5)(x-3)}} dx$

4. $\int e^x \left(\frac{\sin 4x - 4}{1 - \cos 4x} \right) dx$ 5. $\int x^2 \tan^{-1} x dx$ 6. $\int \frac{dx}{\cos^2 x + \sin 2x}$

7. $\int \frac{2x}{(1+x^2)(3+x^2)} dx$ 9. $\int \tan^{-1} \sqrt{\frac{1-x}{1+x}} dx$ 10. $\int_0^{\pi} \frac{x \tan x}{\sec x \operatorname{cosec} x} dx$

11. $\int_0^{\pi} \frac{x}{1 + \sin x} dx$ 12. $\int_{-1}^3 |x^3 - x| dx$ 13. $\int_1^3 \frac{\sqrt{x}}{\sqrt{x} + \sqrt{5-x}} dx$

14. $\int_0^{\frac{\pi}{4}} \log(1 + \tan x) dx$

(5 marks problems)

1. Find the area of the region $\{ (x,y): 0 \leq y \leq x^2 + 1, 0 \leq y \leq x + 1, 0 \leq x \leq 2 \}$

Solution

Sketch the region whose area is to be found out.

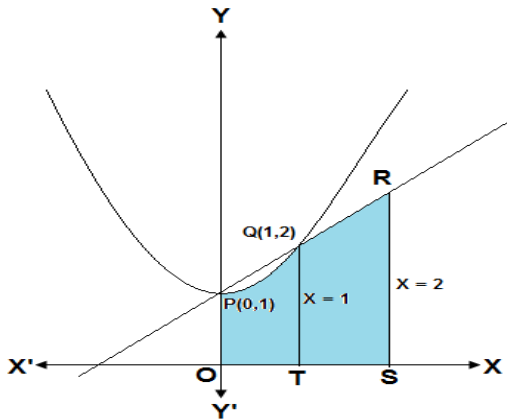

The point of intersection of $y = x^2 + 1$ and $y = x + 1$ are the points $(0, 1)$ and $(1, 2)$

The required area = area of the region OPQRSTO

$$\begin{aligned}
 &= \text{area of the region OTQPO} + \text{area of the region TSRQT} \\
 &= \int_0^1 (x^2 + 1) dx + \int_1^2 (x + 1) dx \\
 &= \left[\frac{x^3}{3} + x \right]_0^1 + \left[\frac{x^2}{2} + x \right]_1^2 \\
 &= \frac{23}{6} \text{ sq.units}
 \end{aligned}$$

5. Find the area cut off from the parabola $4y = 3x^2$ by the line $2y = 3x + 12$

Solution

Given $4y = 3x^2$ and $3x - 2y + 12 = 0$

Solve both the equation we get the point of

intersection of both the curves

$(-2, 3)$ and $(4, 12)$

Required area = area of AOBA

$$\begin{aligned}
 &= \int_{-2}^4 \left[\frac{3x+12}{2} - \frac{3x^2}{4} \right] dx \\
 &= 27 \text{ sq.unts}
 \end{aligned}$$

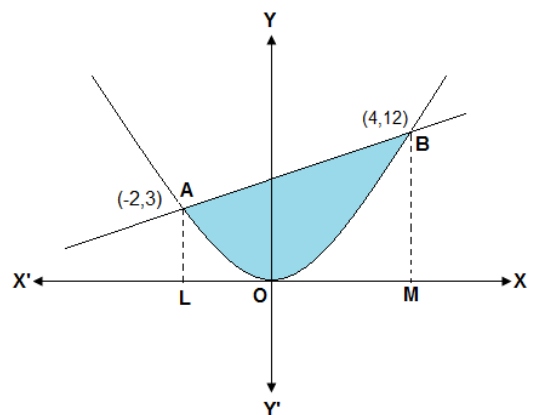

Practice Questions

- Find the area of the region bounded by the parabola $y^2 = 4ax$, its axis and two ordinates $x = 4$ and $x = 9$
- Find the area bounded by the parabola $x^2 = y$, y axis and the line $y = 1$
- Find the area bounded by the curve $y = -x^2$, x axis and the ordinates $x = 1$ and $x = 3$

4. Find the area of the region bounded by the curve $y^2 = 4x$ and the line $x = 3$
5. Find the area of the region $\{ (x,y) : x^2 + y^2 \leq 4, x + y \geq 2 \}$
6. Find the of the circle $x^2 + y^2 = a^2$
7. Find the area of the ellipse $\frac{x^2}{a^2} + \frac{y^2}{b^2} = 1$
8. Find the area of the smaller region bounded by the ellipse $\frac{x^2}{9} + \frac{y^2}{4} = 1$ and the straight line $\frac{x}{3} + \frac{y}{2} = 1$
9. Find the area enclosed by the curve $x = 3 \cos t, y = 2 \sin t$.
10. Find the area bounded by the lines $x + 2y = 2, y - x = 1$ and $2x + y = 7$
11. Find the area of the region bounded by the parabola $y = x^2$ and the line $3x - 2y + 12 = 0$
12. Using integration, find the area of the triangle ABC with vertices A (-1, 0), B (1, 3) and C (3, 2)

Additional Questions

Q 1. Three children Amit(A), Sumit(B) and Rohit(C) are playing in a park with toy telephones and had tightly caught the wires joining telephones to form a triangle as shown in figure:

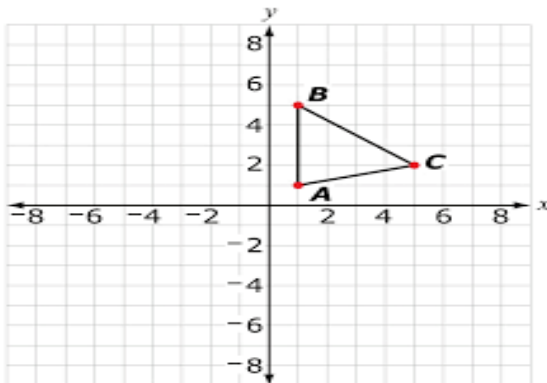

Based on the above information answer the following

questions:

- (i) Find the equation of line representing the wire AB.
 - (ii) Find the equation of line representing the wire BC.
 - (iii) Find the equation of line representing the wire AC.
 - (iv) Also find the area of triangle ABC.
2. Two students A and B are drawn different figures, A is draw a circle of radius 4 cm and B is drawn an ellipse whose semi major and minor axes are 8 cm and 6 cm respectively. Students A clamming that the figure drawn by him covered larger area.
- (i) Sketch both the diagrams
 - (ii) and using integration find which figure is enclosed larger area.

Gist of the lesson :

Basic concepts: $x^2 - 3x + 3 = 0 \dots(1)$ $\sin x + \cos x = 0 \dots(2)$ $x + 2y = 7 \dots\dots(3)$ $x + \frac{dy}{dx} + y = 0 \dots(4)$

$\frac{d^2y}{dx^2} + y = 0 \dots(5)$ $\left(\frac{d^3y}{dx^3}\right) + x^2 \left(\frac{d^2y}{dx^2}\right)^3 = 0 \dots(6)$ Here are six equations.(1), (2), (3) are the equations are respectively quadratic, trigonometric , and linear equations. Whereas (4),(5) and (6) are differential equations. Actually, an equation involving derivative (derivatives) of the dependent variable with respect to independent variable (variables) is called Differential Equation.

IMPORTANT : Sometimes differential involves derivatives with respect to more than one independent variables, such equations are called PARTIAL DIFFERENTIAL EQUATIONS, else it is called ordinary differential equation. Here, we are to learn only about ordinary differential equation.

Order and Degree of differential equation.: The highest order derivative of the dependent variable with respect to independent variable involved in a differential equation is called its ORDER. The highest power of derivative forming polynomial equation in derivatives is called its degree.. e.g The degree of the differential equation. $\frac{dy}{dx} + \sin\left(\frac{dy}{dx}\right) = 0$ is not defined. As it does not form polynomial equation in derivatives like y', y'', y''' etc.; The degree of $\left(\frac{dy}{dx}\right)^2 + \left(\frac{dy}{dx}\right) - \sin^2 y = 0$ is Two.

General and Particular Solutions of Differential Equation: For differential equation $\frac{d^2y}{dx^2} + y = 0 \dots$ (1)

The function $y = f(x) = a \sin(x + b)$ is its General Solution as when its derivative and the value of y are substituted in L.H.S. of (1) R.H.S. are become equal to zero. While the function $y_1 = f_1(x) = 2 \sin\left(x + \frac{\pi}{4}\right)$ is also the solution of the D. E. -(1) Here , the values arbitrary constant a and b are respectively 2 and $\frac{\pi}{4}$., $y_1 = f_1(x) = 2 \sin\left(x + \frac{\pi}{4}\right)$ is called **particular solution**, while $y = f(x) = a \sin(x + b)$ is called **General Solution**. **Note that the number of arbitrary constants in the general solution of a differential equation of order n is n . The number of arbitrary constants in the particular solution of a differential equation of any order is ZERO.**

Methods of solving First Order, First Degree Differential Equations:

There are three methods, (i) Variable Separable (ii) Homogeneous differential equation (iii) Linear differential equation.

(i) Variable Separable :

$$\frac{dy}{dx} = F(x, y) \dots(1) \Rightarrow f(x) dx = f(y)dy$$

Integrating both sides we get $\int f(x)dx = \int f(y)dy \Rightarrow F(x) = F(y) + C$ is the general solution of D.E. -(I)

(ii) Homogeneous differential equation:

To solve a homogeneous differential equation of the type $\frac{dy}{dx} = F(x, y) = g\left(\frac{y}{x}\right) \dots(1)$

We make the substitution $y = v.x \dots\dots(2)$

Differentiating equation 2 w.r.t. x , we get $\frac{dy}{dx} = v + x \frac{dv}{dx} \dots\dots(3)$

Substituting the value of $\frac{dy}{dx}$ from eqn (3) in eqn (1) we get $v + x \frac{dv}{dx} = g(v)$

Or. $x \frac{dv}{dx} = g(v) - v$ -----(4) separating variables in eqn(4) we get

$$\frac{dv}{g(v)-v} = \frac{dx}{x} \text{ -----(5)}$$

Integrating both sides of eqn(5), we get $\int \frac{dv}{g(v)-v} = \int \frac{1}{x} dx + C$ -----(6)

Eqn (6) gives general solution of the differential equation (1) when we replace v by $\frac{y}{x}$.

(iii) Linear differential equation

A differential equation of the form $\frac{dy}{dx} + Py = Q$, where P and Q are constants or functions of x only, is known as first order linear differential equation also $\frac{dx}{dy} + Px = Q$, where P and Q are constants or functions of y only

To Solve $\frac{dy}{dx} + Py = Q$ find Integrating factor (I.F.) = $e^{\int P dx}$

The general solution of $\frac{dy}{dx} + Py = Q$ is $y \cdot (I.F) = \int Q \cdot (I.F) dx + C$ (proceed)

And To Solve $\frac{dx}{dy} + Px = Q$ find Integrating factor (I.F.) = $e^{\int P dy}$

The general solution of $\frac{dx}{dy} + Px = Q$ is $x \cdot (I.F) = \int Q \cdot (I.F) dy + C$ (proceed)

SECTION A (2 MARKS QUESTION)

1. Find the integrating factor of the following differential equation :

$$x \log x \frac{dy}{dx} + y = 2 \log x$$

Ans: $\log x$

2. Find the sum of the degree and the order for the following differential equation :

$$\left(\frac{d^2y}{dx^2}\right) + \sqrt[3]{\frac{dy}{dx}} + (5 + x) = 0$$

Ans: order 2, degree 3 Sum=5

3. Write the integrating factor of differential equation: $(\tan^{-1}y - x)dy = (1 + y^2)dx$

Ans: $e^{\tan^{-1}y}$

4. Find the product of the order and degree of the following differential equation: $x \left(\frac{d^2y}{dx^2}\right)^2 + \left(\frac{dy}{dx}\right)^2 + y^2 = 0$

5. Find the integrating factor of differential equation: $(x^2 + 1) \frac{dy}{dx} + 2xy = \sqrt{x^2 + 4}$

Ans: I. F. = $(x^2 + 1)$

6. Solve the following differential equation: $\frac{dy}{dx} = x^3 \operatorname{cosec} y$, given that $y(0) = 0$.

Ans: $\cos y = 1 - \frac{x^4}{4}$

7. Write the integrating factor of the following differential equation:

Ans: $e^{\tan^{-1}y}$

$$(1 + y^2)dx - (\tan^{-1}y - x)dy = 0$$

SECTION A (3 MARKS QUESTION)

8. Find the general solution of the differential equation $\frac{dy}{dx} = \frac{y^2}{xy - x^2}$ **Ans: $x \log y - y = c$**

9. Find the general solution of the differential equation $\frac{dy}{dx} - y = \sin x$

Ans: $y = -\frac{1}{2}(\sin x + \cos x) + ce^x$

10. Find the particular solution of the differential equation :

$\log\left(\frac{dy}{dx}\right) = 3x + 4y$, given that $y = 0$ when $x = 0$. **Ans: $4e^{3x} + 3e^{-4y} - 7 = 0$**

11. Solve the differential equation : $x \frac{dy}{dx} = y - x \tan\left(\frac{y}{x}\right)$ **Ans: $x \sin \frac{y}{x} = c$**

12. Find the general solution of the equation: $3e^x \tan y dx + (1 - e^x) \sec^2 y dy = 0$

Ans: $(e^x - 1)^3 = Ct \tan y$

13. Solve the following differential equation : $(\tan^{-1}x - y) dx = (1 + x^2) dy$

Ans: $y = (\tan^{-1}x - 1) + c \cdot e^{-\tan^{-1}x}$

14. Solve the differential equation: $(1+x^2) \frac{dy}{dx} + y = e^{\tan^{-1}x}$ **Ans: $y = \frac{1}{2}e^{\tan^{-1}x} + ce^{-\tan^{-1}x}$**

15. Find the general solution of the differential equation:

$y dx - (x + 2y^2) dy = 0$ **Ans: $x = \frac{2}{3}y^2 + \frac{c}{y}$**

16. Find the general solution of the differential equation $\frac{dy}{dx} - y = \sin x$

Ans: $y = -\frac{1}{2}(\sin x + \cos x) + ce^x$

17. Solve: $\frac{dy}{dx} + y \sec x = \tan x$ ($0 \leq x < \frac{\pi}{2}$) **Ans: $y(\sec x + \tan x) = \sec x + \tan x - x + c$**

SECTION A (5 MARKS QUESTION)

18. Solve the following differential equation: $\left[y - x \cos\left(\frac{y}{x}\right)\right] dy + \left[y \cos\left(\frac{y}{x}\right) - 2x \sin\left(\frac{y}{x}\right)\right] dx = 0$

Ans: $y^2 - 2x^2 \cos\left(\frac{y}{x}\right) = C$

19. Solve the following differential equation: $(\sqrt{1+x^2+y^2+x^2y^2}) dx + xy dy = 0$. **Ans:**

$\sqrt{1+y^2} + \sqrt{1+x^2} + \frac{1}{2} \log \left| \frac{\sqrt{1+x^2}-1}{\sqrt{1+x^2}+1} \right| + c$

20. Find a particular solution of differential equation $(x - y)(dx + dy) = dx - dy$, given that $y = -1$, when $x = 0$

Ans: $x + y = \log|x - y| - 1$

21. Solve the differential equation $\left\{x \cos\left(\frac{y}{x}\right) + y \sin\left(\frac{y}{x}\right)\right\} y dx = \left\{y \sin\left(\frac{y}{x}\right) - x \cos\left(\frac{y}{x}\right)\right\} x dy$ **Ans: $xy \cos \frac{y}{x} = A$**

22. Solve the following differential equation, given that $y = 0$, when $x = \frac{\pi}{4}$: $\sin 2x \frac{dy}{dx} - y = \tan x$ **Ans:**

$y = \tan x - \sqrt{\tan x}$

23. Find the particular solution of the differential equation: $\frac{dy}{dx} = -\frac{x+y \cos x}{1+\sin x}$ given that $y = 1$ when $x = 0$

Ans: $y = -\frac{1}{2}x^2 \frac{1}{(1+\sin x)} + \frac{1}{(1+\sin x)}$

24. Find the particular solution of the differential equation: $xe^{\frac{y}{x}} - y \sin\left(\frac{y}{x}\right) + x \frac{dy}{dx} \sin\left(\frac{y}{x}\right) = 0$,

given that $y = 0$, when $x = 1$

Ans: $\left[\sin \frac{y}{x} + \cos \frac{y}{x}\right] e^{-\frac{y}{x}} \log x^2 + 1$

25. Find the particular solution of the differential equation $e^x \tan y dx + (2 - e^x) \sec^2 y dy = 0$, given that

$y = \frac{\pi}{4}$ when $x = 0$.

Ans: $y = 2 - e^x$

KENDRIYA VIDYALAYA SANGATHAN, RAIPUR REGION (2022-23)
CLASS XII –MATHEMATICS
CHAPTER 10 : VECTORS ALGEBRA

SUMMARY

1. Position vector of a point P(x, y, z) is given as $\overrightarrow{OP}(\vec{r}) = x\hat{i} + y\hat{j} + z\hat{k}$, and its magnitude by $\sqrt{x^2 + y^2 + z^2}$.

2. The scalar components of a vector are its direction ratios, and represent its projections along the respective axes.
3. The magnitude(r), direction ratios (a, b, c) and direction cosines (l, m, n) of any vector are related as: $l = \frac{a}{r}, m = \frac{b}{r}, n = \frac{c}{r}$
4. The vector sum of the three sides of a triangle taken in order is 0.
5. The vector sum of two co initial vectors is given by the diagonal of the parallelogram whose adjacent sides are the given vectors.
6. The multiplication of a given vector by a scalar α , changes the magnitude of the given vector by the multiple $|\alpha|$, and keeps the direction same (or makes it opposite) according as the value of α is positive (or negative).
7. For a given vector \vec{a} , the vector $\hat{a} = \frac{\vec{a}}{|\vec{a}|}$ gives the unit vector in the direction of \vec{a} .
8. The position vector of a point R dividing a line segment joining the points P and Q whose position vectors are \vec{a} and \vec{b} respectively, in the ratio $m : n$
 - (i) internally, is given by $\vec{R} = \frac{m\vec{b} + n\vec{a}}{m+n}$.
 - (ii) externally, is given by $\vec{R} = \frac{m\vec{b} - n\vec{a}}{m-n}$.
 - (iii) if R is the mid point of PQ, then $\vec{R} = \frac{\vec{b} + \vec{a}}{2}$.
9. The scalar product of two given vectors \vec{a} and \vec{b} having angle θ between them is defined as $\vec{a} \cdot \vec{b} = |\vec{a}||\vec{b}|\cos \theta$.
Also, when $\vec{a} \cdot \vec{b}$ is given, the angle ' θ ' between the vectors \vec{a} and \vec{b} may be determined by $\cos \theta = \frac{\vec{a} \cdot \vec{b}}{|\vec{a}||\vec{b}|}$.
10. The vector product is given as $\vec{a} \times \vec{b} = |\vec{a}||\vec{b}| \sin \theta \hat{n}$, where \hat{n} is a unit vector perpendicular to the plane containing \vec{a} and \vec{b} such that $\vec{a}, \vec{b}, \hat{n}$ form right handed system of co-ordinate axes.
11. If we have two vectors \vec{a} and \vec{b} , given in component form as

$$\vec{a} = a_1\hat{i} + b_1\hat{j} + c_1\hat{k} \text{ and } \vec{b} = a_2\hat{i} + b_2\hat{j} + c_2\hat{k}$$

and λ any scalar, then

$$\vec{a} + \vec{b} = (a_1 + a_2)\hat{i} + (b_1 + b_2)\hat{j} + (c_1 + c_2)\hat{k}$$

$$\lambda\vec{a} = \lambda a_1\hat{i} + \lambda b_1\hat{j} + \lambda c_1\hat{k}$$

$$\vec{a} \cdot \vec{b} = a_1a_2 + b_1b_2 + c_1c_2$$

$$\text{and } \vec{a} \times \vec{b} = \begin{vmatrix} \hat{i} & \hat{j} & \hat{k} \\ a_1 & b_1 & c_1 \\ a_2 & b_2 & c_2 \end{vmatrix}$$

MULTIPLE CHOICE QUESTIONS

Select the correct alternative:

1. The vector in the direction of the vector $\hat{i} - 2\hat{j} + 2\hat{k}$ that has magnitude 9 is

(a) $\hat{i} - 2\hat{j} + 2\hat{k}$

(b) $\frac{\hat{i} - 2\hat{j} + 2\hat{k}}{3}$

(c) $3(\hat{i} - 2\hat{j} + 2\hat{k})$

(d) $9(\hat{i} - 2\hat{j} + 2\hat{k})$

2. The angle between two vectors \vec{a} and \vec{b} with magnitude $\sqrt{3}$ and 4, respectively and $\vec{a} \cdot \vec{b} = 2\sqrt{3}$ is

- (a) $\frac{\pi}{6}$ (b) $\frac{\pi}{3}$ (c) $\frac{\pi}{2}$ (d) $\frac{5\pi}{2}$

3. If $|\vec{a}| = 10$, $|\vec{b}| = 2$ and $\vec{a} \cdot \vec{b} = 12$, then the value of $|\vec{a} \times \vec{b}|$ is

- (a) 5 (b) 10 (c) 14 (d) 16

Answer

1.b 2.a 3.d

Practice problems

Very Short Answer Questions (2 Marks)

- 1) Find the projection of $\hat{i} - \hat{j}$ on $\hat{i} + \hat{j}$.
- 2) If $|\vec{a}| = 2$, $|\vec{b}| = \sqrt{3}$ and $\vec{a} \cdot \vec{b} = \sqrt{3}$. Find the angle between \vec{a} and \vec{b} .
- 3) Find the value of λ when the projection of $\vec{a} = \lambda\hat{i} + \hat{j} + 4\hat{k}$ on $\vec{b} = 2\hat{i} + 6\hat{j} + 3\hat{k}$ is 4 units.

Short answer type questions (3 Marks)

1. Find the angle between the vectors $\hat{i} - 2\hat{j} + 3\hat{k}$ and $3\hat{i} - 2\hat{j} + \hat{k}$.
2. Find $|\vec{a} - \vec{b}|$ if $|\vec{a}| = 2$, $|\vec{b}| = 3$ and $\vec{a} \cdot \vec{b} = 4$.
3. If \vec{a} is a unit vector and $(\vec{x} - \vec{a}) \cdot (\vec{x} + \vec{a}) = 15$. Find $|\vec{x}|$.
4. If \vec{a} and \vec{b} are two vectors such that $|\vec{a} + \vec{b}| = |\vec{a}|$ then prove that the vector $2\vec{a} + \vec{b}$ is perpendicular to \vec{b} .
5. If vectors $\vec{a} = 2\hat{i} + 2\hat{j} + 3\hat{k}$, $\vec{b} = \hat{i} + \hat{j} + \hat{k}$ and $\vec{c} = 3\hat{i} + \hat{j}$ are such that $\vec{a} + \lambda\vec{b}$ is perpendicular to \vec{c} . Find the value of λ .
6. If A and B be two points with position vectors $2\hat{i} - \hat{j} + 2\hat{k}$ and $\hat{i} + 2\hat{j}$ respectively. Find the position vector of the point which divides AB in 1 : 2 internally.

Long answer type questions (5 Marks)

1. Find the value of p so that $\vec{a} = 2\hat{i} + p\hat{j} + \hat{k}$ and $\vec{b} = \hat{i} - 2\hat{j} + 3\hat{k}$ are perpendicular to each other.
2. Find $|\vec{a}|$ if $|\vec{a}| = 2|\vec{b}|$ and $(\vec{a} + \vec{b}) \cdot (\vec{a} - \vec{b}) = 12$.
3. If $|\vec{a} + \vec{b}| = 60$, $|\vec{a} - \vec{b}| = 40$ and $|\vec{b}| = 46$. Find $|\vec{a}|$.
4. If $\vec{a} = (3\hat{i} + 2\hat{j} - 3\hat{k})$ and $\vec{b} = (4\hat{i} + 7\hat{j} - 3\hat{k})$. Find vector projection of \vec{a} in the direction of \vec{b} .
5. The two adjacent sides of a parallelogram are $(2\hat{i} - 4\hat{j} + 5\hat{k})$ & $(\hat{i} - 2\hat{j} - 3\hat{k})$. Find the unit vectors parallel to its diagonals. Also find its area.
6. If $(\hat{i} + \hat{j} + \hat{k})$, $(2\hat{i} + 5\hat{j} - 3\hat{k})$, $(3\hat{i} + 2\hat{j} - 2\hat{k})$ & $(\hat{i} - 6\hat{j} - \hat{k})$ are the position vectors of points A, B, C & D respectively, then find the angle between AB & CD. Deduce that AB & CD are parallel.
7. The scalar product of the vector $\vec{a} = \hat{i} + \hat{j} + \hat{k}$ with a unit vector along the sum of the vectors $\vec{b} = 2\hat{i} + 4\hat{j} - 5\hat{k}$ and $\vec{c} = \mu\hat{i} + 2\hat{j} + 3\hat{k}$ is equal to one. Find the value of μ and hence find the unit vector along $\vec{b} + \vec{c}$.

KENDRIYA VIDYALAYA SANGATHAN, RAIPUR REGION (2022-23)
CLASS XII – MATHEMATICS
CHAPTER 11 : 3D GEOMETRY

Summary

- Distance formula:** Distance between two points A(x_1, y_1, z_1) and B (x_2, y_2, z_2) is

$$AB = \sqrt{(x_2 - x_1)^2 + (y_2 - y_1)^2 + (z_2 - z_1)^2}$$
 - Section formula:** Coordinates of a point P, which divides the line segment joining two given points A(x_1, y_1, z_1) and B(x_2, y_2, z_2) in the ratio $m : n$
 - internally, are P $\left(\frac{mx_2 + nx_1}{m+n}, \frac{my_2 + ny_1}{m+n}, \frac{mz_2 + nz_1}{m+n}\right)$,
 - the coordinates of a point Q divides the line segment joining two given points in the ratio $m : n$; externally are Q $\left(\frac{mx_2 - nx_1}{m-n}, \frac{my_2 - ny_1}{m-n}, \frac{mz_2 - nz_1}{m-n}\right)$
 - the coordinates of mid-point are R $\left(\frac{x_2 + x_1}{2}, \frac{y_2 + y_1}{2}, \frac{z_2 + z_1}{2}\right)$
 - Direction cosines of a line :**
 - The direction of a line OP is determined by the angles α, β, γ which makes with OX, OY, OZ respectively. These angles are called the direction angles and their cosines are called the direction cosines.
 - Direction cosines of a line are denoted by l, m, n ; $l = \cos \alpha, m = \cos \beta, n = \cos \gamma$
 - Sum of the squares of direction cosines of a line is always 1.
 $l^2 + m^2 + n^2 = 1$ i.e $\cos^2 \alpha + \cos^2 \beta + \cos^2 \gamma = 1$
 - Direction ratio of a line :**
 - Numbers proportional to the direction cosines of a line are called direction ratios of a line. If $a, b,$ and c are, direction ratios of a line, then

$$\frac{l}{a} = \frac{m}{b} = \frac{n}{c}$$
 - If a, b, c are, direction ratios of a line, then the direction cosines are

$$\pm \frac{a}{\sqrt{a^2 + b^2 + c^2}}, \pm \frac{b}{\sqrt{a^2 + b^2 + c^2}}, \pm \frac{c}{\sqrt{a^2 + b^2 + c^2}}$$
 - Direction ratio of a line AB passing through the points A(x_1, y_1, z_1) and B (x_2, y_2, z_2) are $x_2 - x_1, y_2 - y_1, z_2 - z_1$
 - STRAIGHT LINE:**
 - Vector equation of a Line passing through a point \vec{a} and along the direction \vec{b} , : $\vec{r} = \vec{a} + \mu \vec{b}$,
 - Cartesian equation of a Line: $\frac{x-x_1}{a} = \frac{y-y_1}{b} = \frac{z-z_1}{c}$. Where (x_1, y_1, z_1) is the given point and its direction ratios are a, b, c .
 - Vector equation of a Line passing through two points, with position vectors \vec{a} and \vec{b}

$$\vec{r} = \vec{a} + \mu(\vec{b} - \vec{a})$$
 - Cartesian equation of a Line: $\frac{x-x_1}{x_2-x_1} = \frac{y-y_1}{y_2-y_1} = \frac{z-z_1}{z_2-z_1}$, two points are (x_1, y_1) and (x_2, y_2).
 - ANGLE** between two lines (i) Vector equations: $\vec{r} = \vec{a}_1 + \lambda \vec{b}_1$ and $\vec{r} = \vec{a}_2 + \mu \vec{b}_2$,
- (ii) Cartesian equations: If lines are $\frac{x-x_1}{a_1} = \frac{y-y_1}{b_1} = \frac{z-z_1}{c_1}$, $\frac{x-x_2}{a_2} = \frac{y-y_2}{b_2} = \frac{z-z_2}{c_2}$

$$\cos \theta = \frac{\vec{b}_1 \cdot \vec{b}_2}{|\vec{b}_1| \cdot |\vec{b}_2|}$$

(iii) If two lines are perpendicular, then $\vec{b}_1 \cdot \vec{b}_2 = 0$, i.e. $a_1a_2 + b_1b_2 + c_1c_2 = 0$

(iv) If two lines are parallel, then $\vec{b}_1 = t \vec{b}_2$, where t is a scalar. OR $\vec{b}_1 \times \vec{b}_2 = 0$, OR $\frac{a_1}{a_2} =$

$$\frac{b_1}{b_2} = \frac{c_1}{c_2}$$

(v) If θ is the angle between two lines with direction cosines, l_1, m_1, n_1 and l_2, m_2, n_2 then

(a) $\cos \theta = l_1l_2 + m_1m_2 + n_1n_2$ (b) if the lines are parallel, then $\frac{l_1}{l_2} = \frac{m_1}{m_2} = \frac{n_1}{n_2}$

(c) If the lines are perpendicular, then $l_1l_2 + m_1m_2 + n_1n_2 = 0$

8 Shortest distance between two skew- lines:

(i) Vector equations: $\vec{r} = \vec{a}_1 + \lambda \vec{b}_1$, and $\vec{r} = \vec{a}_2 + \mu \vec{b}_2$,

$$SD = \left| \frac{(\vec{a}_2 - \vec{a}_1) \cdot (\vec{b}_1 \times \vec{b}_2)}{|\vec{b}_1 \times \vec{b}_2|} \right|$$

If shortest distance is zero, then lines intersect and line intersects in space if they are coplanar. Hence if above lines are coplanar

If $(\vec{a}_2 - \vec{a}_1) \cdot (\vec{b}_1 \times \vec{b}_2) = 0$

(ii) Cartesian equations: $\frac{x-x_1}{a_1} = \frac{y-y_1}{b_1} = \frac{z-z_1}{c_1}$, $\frac{x-x_2}{a_2} = \frac{y-y_2}{b_2} = \frac{z-z_2}{c_2}$

$$SD = \left| \frac{\begin{vmatrix} x_2-x_1 & y_2-y_1 & z_2-z_1 \\ a_1 & b_1 & c_1 \\ a_2 & b_2 & c_2 \end{vmatrix}}{\sqrt{(b_1c_2-b_2c_1)^2 + (c_1a_2-c_2a_1)^2 + (a_1b_2-a_2b_1)^2}} \right|$$

If shortest distance is zero, then lines intersect and line intersects in space if they are coplanar. Hence if above lines are coplanar

$$\begin{vmatrix} x_2-x_1 & y_2-y_1 & z_2-z_1 \\ a_1 & b_1 & c_1 \\ a_2 & b_2 & c_2 \end{vmatrix} = 0$$

9. Shortest distance between two parallel lines:

If two lines are parallel, then they are coplanar. Let the lines be: $\vec{r} = \vec{a}_1 + \lambda \vec{b}$, and:

$$\vec{r} = \vec{a}_2 + \mu \vec{b}, \quad SD = \left| \frac{\vec{b} \times (\vec{a}_2 - \vec{a}_1)}{|\vec{b}|} \right|$$

FLOW CHART

(a) To find shortest distance between two skew lines

- 1 Find $\vec{a}_1, \vec{a}_2, \vec{b}_1$ & \vec{b}_2
- 2 Find $\vec{a}_2 - \vec{a}_1$
- 3 Find $\vec{b}_1 \times \vec{b}_2$
- 4 Find $|\vec{b}_1 \times \vec{b}_2|$
- 5 $(\vec{b}_1 \times \vec{b}_2) \cdot (\vec{a}_2 - \vec{a}_1)$
- 6 Distance = $\left| \frac{(\vec{b}_1 \times \vec{b}_2) \cdot (\vec{a}_2 - \vec{a}_1)}{|\vec{b}_1 \times \vec{b}_2|} \right|$

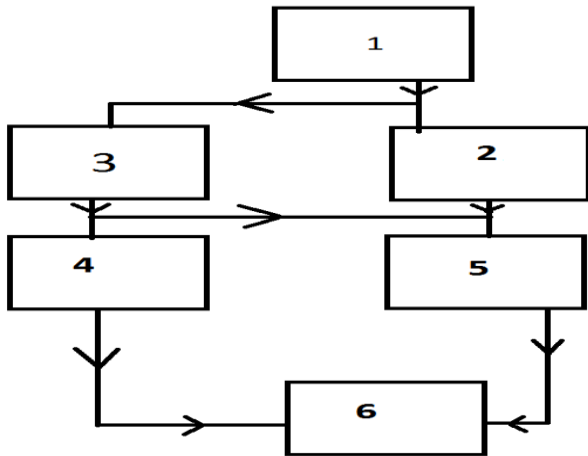

MULTIPLE TYPE QUESTIONS

Choose the correct alternative.

1. Distance of the point (a,b,c) from y axis is
 (a) b (b) |b| (c) |b|+|c| (d) $\sqrt{a^2 + b^2}$
2. If the direction cosine of a line are k,k,k, then
 (a) k>0 (b) 0<k<1 (c) k=1 (d) $k = \frac{1}{\sqrt{3}}, k = -\frac{1}{\sqrt{3}}$

QUESTIONS ON 3-D.

Very short answer type questions(2 Marks)

1. The equation of a line is given by $\frac{4-x}{2} = \frac{y+3}{3} = \frac{z+2}{6}$. Write the direction cosines of a line parallel to given line.
2. Find the shortest distance between the following pair of lines :

$$\frac{x-1}{2} = \frac{y-2}{3} = \frac{z-3}{4}; \quad \frac{x-2}{3} = \frac{y-4}{4} = \frac{z-5}{5}$$

Short type questions (3 -Marks)

1. Find the values of p so that the lines: $\frac{1-x}{3} = \frac{7y-14}{2p} = \frac{z-3}{2}$ and $\frac{7-7x}{3p} = \frac{y-5}{1} = \frac{6-z}{5}$ are at right angles.

2. Find the shortest distance between the lines $x + 1 = 2y = -12z$ and $x = y + 2 = 6z - 6$

4. Find the shortest distance between the following pair of lines :

$$\frac{x-1}{2} = \frac{y+1}{3} = z ; \quad \frac{x+1}{5} = \frac{y-2}{1} ; \quad z = 2$$

Long answer type questions(5 Marks)

1. Find a unit vector perpendicular to the plane of the triangle ABC, where the coordinates of its vertices are A (3, -1, 2), B (1, -1, -3) and C (4, -3, 1).

2. Find the image of the point (1, 6, 3) in the line $\frac{x}{1} = \frac{y-1}{2} = \frac{z-2}{3}$.

3 Find the shortest distance between the lines whose vector equations are:

$$\vec{r} = (1-t)\hat{i} + (t-2)\hat{j} + (3-2t)\hat{k} \text{ and } \vec{r} = (s+1)\hat{i} + (2s-1)\hat{j} - (2s+1)\hat{k}$$

COMPETENCY BASED QUESTIONS

1.A building of a multinational company is to be constructed in the form of a triangle pyramid, ABCD as shown in the figure. A Shanghai building is in the form of a triangular pyramid with floor ABD and vertex C

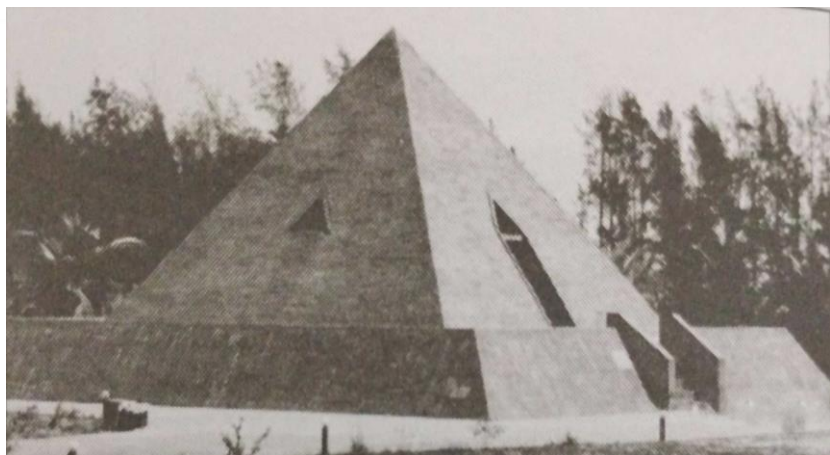
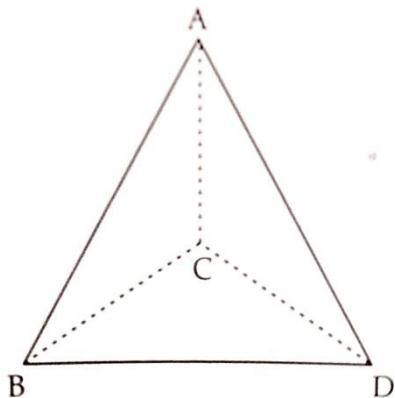

Let its angular points are A(3,0,1), B(-1,4,1), C(5,2,3) and D (0,-5,4) and G be the point of intersection of the medians of ABCD.

Based on the above data, answer the following

(i) Find the coordinate of the point G.

(ii) What is the length of the vector \vec{AG}

(iii) Find the area of triangle ABC (in sq.units)

OR

(iii) Find the sum of the length of \overrightarrow{AB} and \overrightarrow{AC} is

Answers of Competency based question:

1. $(\frac{4}{3}, \frac{1}{3}, \frac{8}{3})$ (ii) $\frac{\sqrt{51}}{2}$ (iii) $4\sqrt{6}$ OR (iii) 8.7 units

KENDRIYA VIDYALAYA SANGATHAN, RAIPUR REGION (2022-23)
CLASS XII –MATHEMATICS
CHAPTER 12 - LINEAR PROGRAMMING PROBLEMS

LINEAR PROGRAMMING PROBLEM(LPP)

A linear programming problem deals with the optimization (maximization/ minimization) of a linear function of two variables (say x and y) which is known as objective function subject to :

- i) The variables x and y are non-negative
- ii) The variables x and y satisfy a set of linear inequalities which are called linear constraints.

OBJECTIVE FUNCTION

A linear function $z = ax + by$ where a and b are constants which has to be maximized or minimized is called a linear objective function.

DECISION VARIABLES

In the objective function $z = ax + by$, x and y are called decision variables.

CONSTRAINTS

The linear inequalities or restrictions on the variables of an LPP are called constraints. The conditions $x \geq 0$, $y \geq 0$ are called non-negative constraints.

FEASIBLE REGION

The common region determined by all the constraints including non-negative constraints $x \geq 0$, $y \geq 0$ of an LPP is called the feasible region for the problem.

FEASIBLE SOLUTIONS

Points within and on the boundary of the feasible region for an LPP represent feasible solutions.

INFEASIBLE SOLUTIONS

Any point outside feasible region is called infeasible solutions.

OPTIMAL(FEASIBLE) SOLUTION

Any point in the feasible region that gives the optimal value (maximum or minimum) of the objective function is called an optimal solution.

THEOREM-1

Let R be the feasible region (convex polygon) for an LPP and $Z=ax + by$ be the objective function. When Z has an optimal value (maximum or minimum) where x and y are subject to constraints described by linear inequalities, this optimal value must occur at a corner point(vertex) of the feasible region.

THEOREM-2

Let R be the feasible region for a LPP and $Z = ax + by$ be the objective function. If R is bounded, then the objective function Z has both a maximum and a minimum value on R and each of these occur at a corner point of R .

If the feasible region R is unbounded, then a maximum or a minimum value of the objective function may or may not exist. If it exists, it must occur at a corner point of R .

CORNER POINT METHOD FOR SOLVING A LPP

The method comprises of the following steps:

1) Find the feasible region of the LPP and determine its corner points(vertices) either by inspection or by solving the two equations of the lines intersecting at the point.

2) Evaluate the objective function $Z = ax + by$ at each corner point.

Let M and m respectively denote the largest and the smallest values of Z .

3).i) When the feasible region is bounded , M and m are respectively the maximum and minimum values of Z .

ii) In case the feasible region is unbounded

a) M is maximum value of Z , if the open half plane determined by $ax+by > M$ has no point in common with the feasible region. Otherwise Z has no maximum value.

b) Similarly , m is minimum value of Z , if the open half plane determined by $ax+by < m$ has no common point with the feasible region. Otherwise Z has no minimum value.

MULTIPLE OPTIMAL POINTS

If two corner points of the feasible region are optimal solutions of the same type i.e. both produce the same maximum or minimum , then any point on the line segment joining these two points is also an optimal solution of the same type.

5 MARKS QUESTIONS

1.Solve the following linear programming problem graphically:

Maximise $Z = 3x+4y$

Subject to the constraints

$$x+y \leq 4$$

$$x \geq 0, y \geq 0$$

Ans: Maximum value of Z is 16 at the point (0,4)

2. Solve the following linear programming problem graphically:

Maximise $Z = 4x+y$

Subject to the constraints

$$x+y \leq 50$$

$$3x+y \leq 90$$

$$x \geq 0, y \geq 0$$

Ans: Maximum value of Z is 120 at the point (30,0)

3. Maximize: $Z = x+2y$

Subject to the constraints

$$x+2y \geq 100$$

$$2x-y \leq 0$$

$$2x+y \leq 200$$

$$x \geq 0, y \geq 0$$

Solve the above LPP graphically.

Ans: Maximum value of Z is 400 at the point (0,200)

4. The corner points of the feasible region determined by the system of linear constraints are as shown below:

.

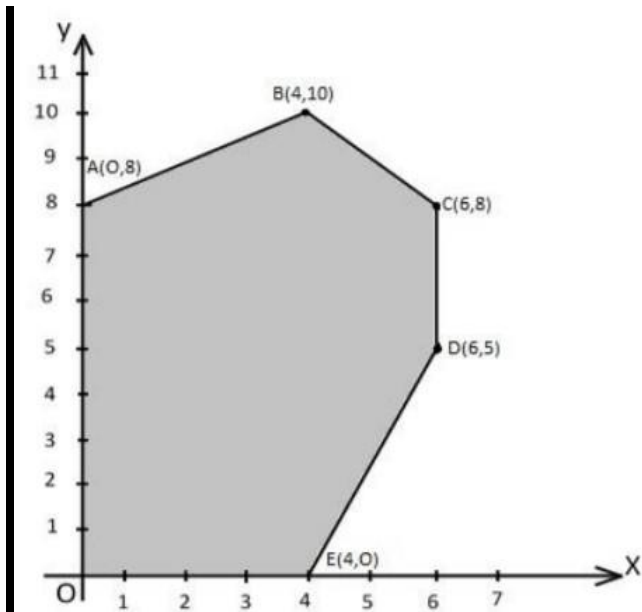

Answer each of the following:

- i) Let $Z = 3x - 4y$ be the objective function. Find the maximum and minimum value of Z and also the corresponding points at which the maximum and minimum value occurs.
- ii) Let $Z = px + qy$, where $p, q > 0$ be the objective function. Find the condition on p and q so that the maximum value of occurs at $B(4,10)$ and $C(6,8)$. Also mention the number of optimal solutions in this case.

Ans: i) Maximum $Z = 12$ at $(4,0)$ and Minimum $Z = -32$ at $(0,8)$ ii) Number of optimal solutions are infinite

5. Solve the following linear programming problem graphically:

Maximise $Z = 3x + 9y$

Subject to the constraints

$$x + 3y \leq 60$$

$$x + y \geq 10$$

$$x \leq y$$

$$x \geq 0, y \geq 0$$

Ans: Maximum value of Z occurs at two corner points $(15,15)$ and $(0,20)$ and maximum value is 180 in each case.

1 MARK QUESTIONS

1. The solution of set of inequality $3x + 5y < 4$ is

- a) an open half-plane not containing the origin
- b) an open half-plane containing the origin
- c) the whole xy -plane not containing the line $3x + 5y = 4$
- d) a closed half plane containing the origin

2. The corner points of the shaded unbounded feasible region of an LPP are $(0,4)$, $(0.6,1.6)$ and $(3,0)$ as shown in the figure. The minimum value of the objective function $Z = 4x + 6y$ occurs at

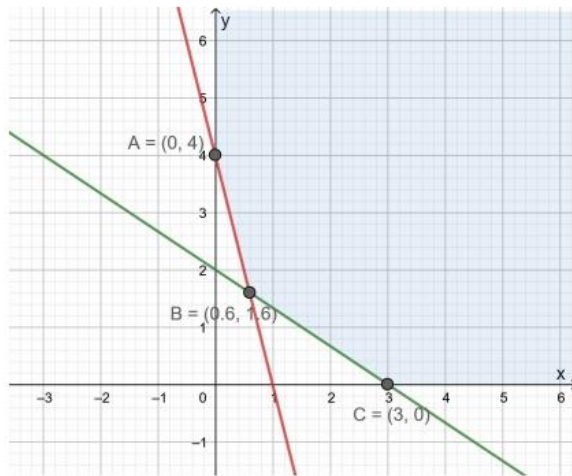

- a) $(0.6, 1.6)$ only b) $(3, 0)$ only
 c) $(0.6, 1.6)$ and $(3, 0)$ only d) at every point of the line segment joining the points $(0.6, 1.6)$ and $(3, 0)$
3. Based on the given shaded region as the feasible region in the graph, at which point(s) is the objective function $Z = 3x + 9y$ maximum ?

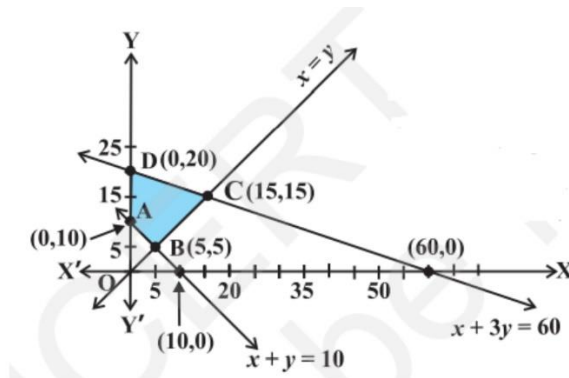

- a) Point B b) point C c) Point D d) every point on the line segment CD
4. A linear programming problem is as follows:
 Minimise $Z = 30x + 50y$
 Subject to constraints,
 $3x + 5y \geq 15$
 $2x + 3y \geq 18$
 $x \geq 0, y \geq 0$
- In the feasible region, the minimum value of Z occurs at
- a) A unique point c) no point
 b) Infinitely many points d) two points only
5. For an objective function $Z = ax + by$, where $a, b > 0$; the corner points of the feasible region determined by a set of constraints (linear inequalities) are $(0, 20)$, $(10, 10)$, $(30, 30)$ and $(0, 40)$. The condition on a and b such that the maximum Z occurs at both the points $(30, 30)$ and $(0, 40)$ is:
- a) $b - 3a = 0$ c) $a = 3b$

b) $a+2b=0$ d) $2a-b=0$

6. In a linear programming problem, the constraints on the decision variables x and y are $x-3y \geq 0, y \geq 0, 0 \leq x \leq 3$. The feasible region
- a) Is not in the first quadrant
 - b) Is bounded in the first quadrant
 - c) Is unbounded in the first quadrant
 - d) Does not exist.

CLASS XII –MATHEMATICS
CHAPTER 13 : PROBABILITY

Random Experiment:

An experiment whose outcomes can't be predicted is called a random experiment.

Trial:

Performing an event is known as trial.

Event:

The possible outcomes of a trial are called events.

Equally likely Events:

The events are said to be equally likely if there is no reason to expect any one in preference to any other.

Exhaustive Events:

The events $E_1, E_2, E_3, \dots, E_n$ of a sample space S are called Exhaustive events if

$$E_1 \cup E_2 \cup E_3 \cup \dots \cup E_n = S$$

Mutually Exclusive Events:

Two or more events are said to be mutually exclusive if they cannot happen simultaneously in a trial.

Favourable Events:

The cases which ensure the occurrence of the events are called favourable events.

Sample Space(S):

The set of all possible outcomes of an experiment is called sample space.

Probability of occurrences of an event:

Probability of occurrences of an event A , denoted by $P(A)$, is defined as:

$$P(A) = \frac{\text{Number of outcomes in favour of } A}{\text{Total number of possible outcomes}} = \frac{n(A)}{n(S)}$$

THEOREMS:

(i) In a random experiment, if S be the sample space and A an event, then:

$$(a) 0 \leq P(A) \leq 1 \quad (b) P(\emptyset) = 0 \quad (c) P(S) = 1$$

(ii) If A and B are mutually exclusive events, then

$$(a) P(A \cap B) = 0 \quad (b) P(A) + P(B) = 1 \quad (c) P(A \cup B) = P(A) + P(B)$$

(iii) For any two events A and B $P(A \cup B) = P(A) + P(B) - P(A \cap B)$

(iv) For each event A, $P(\text{not } A) = 1 - P(A)$, where 'not A' is the complementary event of A.

MORE DEFINITIONS

Compound Event:

The simultaneous happening of two or more events is called a compound event if they occur in connection with each other.

Conditional Probability:

Let A and B be two events associated with the same sample space S, then Probability of occurrences of event A given that B occurs is

$$P(A/B) = \frac{P(A \cap B)}{P(B)}, P(B) \neq 0$$

Independent Events:

Two events are said to be independent if the occurrence of one does not depend upon the occurrence of the other.

$$P(A \cap B) = P(A) \cdot P(B) \quad \text{when A and B are independent events.}$$

MULTIPLICATION THEOREM:

Let A and B be two events associated with the same sample space. Then

$$P(A \cap B) = P(B) \cdot P(A / B), \quad \text{where } P(B) \neq 0$$

THEOREM ON TOTAL PROBABILITY:

If $E_1, E_2, E_3, \dots, E_n$ are mutually exclusive and exhaustive events (partition) of sample space S and A is any event associated with S, then

$$P(A) = P(E_1) \cdot P(A | E_1) + P(E_2) \cdot P(A | E_2) + P(E_3) \cdot P(A | E_3) + \dots + P(E_n) \cdot P(A | E_n)$$

BAYES' THEOREM:

If $E_1, E_2, E_3, \dots, E_n$ are mutually exclusive and exhaustive events (partition) of sample space S and A is any event associated with S, then

$$P(E_i / A) = \frac{P(E_i)P(A/E_i)}{P(E_1)P(A/E_1) + P(E_2)P(A/E_2) + P(E_3)P(A/E_3) + \dots + P(E_n)P(A/E_n)}$$

RANDOM VARIABLE

A random variable is a real valued function defined over the sample space of an experiment

Consider two coins, which are tossed simultaneously

Here the sample space is given by: $S = \{HH, HT, TH, TT\}$.

If X denotes the number of heads, then

$$X(HH)=2, X(HT) = 1, X(TH) = 1, X(TT)= 0$$

Thus, X takes the values 0, 1,2

PROBABILITY DISTRIBUTION OF A RANDOM VARIABLE:

Let X be the random variable. Then the table of Probability Distribution of X is as:

X	x_1	x_2	x_n
P(X)	p_1	p_2	p_n

The values x_1, x_2, \dots, x_n together with their corresponding probabilities p_1, p_2, \dots, p_n form a probability distribution of the random variable X.

MEAN OF A RANDOM VARIABLE:

Let X be a random variable whose possible values x_1, x_2, \dots, x_n occur with probabilities p_1, p_2, \dots, p_n respectively. Then mean of X (denoted by μ) is given by

$$\mu = E(X) = \sum_{i=1}^n x_i p_i$$

QUESTIONS

Case Study

1. A shopkeeper sells three types of flower seeds A_1, A_2, A_3 . They are sold in the form of mixture, where the proportions of the seeds are 4:4:2 respectively. The germination rates of the three types of seeds are 45%, 60% and 35% respectively.



Based on the above information, answer the following:

- (i) Calculate the probability that a randomly chosen seed will germinate
- (ii) Calculate the probability that the seed is of type A_2 , given that a randomly chosen seed germinates.

2. A coach is training 3 players. He observes that the player A can hit a target 4 times in 5 shots, player B can hit 3 times in 4 shots and the player C can hit 2 times in 3 shots. Based on the above information, answer the following:

- (i) The probability that A, B and C all will hit is:
- (ii) Referring to above, what is the probability that B, C will hit and A will lose?
- (iii) With reference to the events mentioned above what is the probability that 'any two of A, B and C, will hit' ?
- (iv) What is the probability that 'none of them will hit the target' ?
- (v) What is the probability that at least one of A, B or C will hit the target?

3. The reliability of a COVID PCR test is specified as follows:

Of people having COVID, 90% of the test detects the disease by 10% goes undetected. Of people free of COVID, 99% of the test is judged COVID negative but 1% are diagnosed as showing COVID positive. From a large population of which only 0.1% have COVID, one person is selected at random, given the COVID PCR test and the pathologist reports him/ her as COVID positive. Based on the above information, answer the following:



- (i) What is the probability of the 'person to be tested as COVID positive' given that 'he is actually having COVID' ?
- (ii) What is the probability of the 'person to be tested as COVID positive' given that 'he is actually not having COVID' ?
- (iii) What is the probability that the 'person is actually not having COVID' ?
- (iv) What is the probability that the 'person is actually having COVID' given that 'he is tested as COVID positive' ?
- (v) What is the probability that the 'person selected will be diagnosed as COVID positive'?

ASSERTION-REASON TYPE QUESTIONS

Each of the following questions contains two statements: Assertion (A) and Reason (R). Each of the questions has four alternative choices, only one of which is the correct statement.

- (a) Both 'A' and 'R' are true and 'R' is the correct explanation of 'A'.
- (b) Both 'A' and 'R' are true but 'R' is not the correct explanation of 'A'.
- (c) 'A' is true but 'R' is false.
- (d) 'A' is false but 'R' is true.

4. **Assertion (A):** Probability that leap year, selected at random, containing 53 Sundays is $\frac{2}{7}$
Reason (R): Leap year contains 366 days.
5. **Assertion (A):** If A and B are two independent events and $P(A) = 1/2$, $P(B) = 1/5$ then $P(A/B) = 1/2$
Reason (R): $P(A/B) = P(A)$.
6. **Assertion (A):** A is any event and $P(B) = 1$, then A and B are independent.
Reason (R): If $P(A \cap B) = P(A) \cdot P(B)$ then A and B are independent.
7. **Assertion (A):** If $P(A/B) \geq P(A)$, then $P(B/A) \geq P(B)$.
Reason (R): $P(A/B) = \frac{P(A \cap B)}{P(B)}$
8. **Assertion (A):** If A and B be two events in a sample space such that $P(A) = 0.3$, $P(B) = 0.3$ then $P(A \cap \bar{B})$ can't be found.
Reason (R): $P(A \cap \bar{B}) = P(A) - P(A \cap B)$

Multiple Choice Questions

9. Let A and B be two events. If $P(A) = 0.2$, $P(B) = 0.4$, $P(A \cup B) = 0.6$, then $P(A/B)$ is equal to :
 (a) 0.8 (b) 0.5 (c) 0.3 (d) 0.
10. Let A and B be two events such that $P(A) = 0.6$, $P(B) = 0.2$ and $P(A/B) = 0.5$ Then $P(A'/B')$ equals:
 (a) 1/10 (b) 3/10 (c) 3/8 (d) 6/7
11. Let 'X' be a random variable. The probability distribution of X is given below:
- | | | | |
|------|-----|------|-----|
| X | 30 | 10 | -10 |
| P(X) | 1/5 | 3/10 | 1/2 |
- Then $E(X)$ is equal to:
 (a) 6 (b) 4 (c) 3 (d) (-5).
12. If A and B are two independent events with $P(A) = 1/3$ and $P(B) = 1/4$ then $P(B'/A)$ is equal to
 (a) 1/4 (b) 1/3 (c) 3/4 (d) 1
13. From the set {1, 2, 3, 4, 5}, two numbers a and b ($a \neq b$) are chosen at random. The probability that a/b is an integer is:
 (a) 1/3 (b) 1/4 (c) 1/2 (d) 3/5
14. A bag contains 3 white, 4 black and 2 red balls. If 2 balls are chosen at random (without replacement), then the probability that both the balls are white is:
 (a) 1/18 (b) 1/36 (c) 1/12 (d) 1/24
15. Three dice are thrown simultaneously. The probability of obtaining a total score of 5 is:
 (a) 5/216 (b) 1/6 (c) 1/36 (d) 1/49
16. A problem is given to three students, whose chances of solving are 1/3, 2/7 and 3/8 The probability that all of them solved the problem is:
 (a) 28/54 (b) 59/84 (c) 62/83 (d) 1/28
17. If A and B are two events such that $P(A) = 0.2$, $P(B) = 0.4$ and $P(A \cup B) = 0.5$, then value of $P(A/B)$ is:

- (a) 0.1 (b) 0.25 (c) 0.5 (d) 0.08
18. If E and F are independent events, $P(E) = 1/2$ and $P(F) = 1/3$ and then $P(E \cap F)$ is:
 (a) $1/2$ (b) $1/3$ (c) 0 (d) $1/6$
19. The probability of obtaining an even prime number on each die, when a pair of dice is rolled is:
 (a) 0 (b) $1/3$ (c) $1/12$ (d) $1/36$
20. If $P(A) = 0.8$, $P(B) = 0.5$ and $P(B/A) = 0.4$, then $P(A \cap B)$ is:
 (a) 0.15 (b) 0.23 (c) 0.32 (d) 0.51

SHORT ANSWER QUESTIONS (2 marks each)

21. A random variable X has the following distribution table:

X	0	1	2	3	4	5	6	7
P(X)	0	k	2k	2k	3k	k^2	$2k^2$	$7k^2 + k$

Determine (i) k (ii) $P(X < 3)$

22. A family has two children. What is the probability that both the children are boys given that at least one of them is a boy?
23. If A and B are two independent events such that $P(\bar{A} \cap B) = \frac{2}{15}$ and $P(A \cap \bar{B}) = \frac{1}{6}$, then find $P(A)$ and $P(B)$.
24. A bag contains four balls. Two balls are drawn from the bag and found to be white. Find the probability that all balls are white.

SHORT ANSWER QUESTIONS (3 marks each)

25. A speaks truth in 70% of the cases and B speaks truth in 80 % of the cases .In what percentage of the cases: (i) they contradict each other in stating the same fact? (ii)they agree each other in stating the same fact?
26. Two numbers are selected at random (without replacement) from the first five positive integers. Let X denote the larger of the two numbers obtained. Find the mean of X .
27. A man is known to speak truth 3 out of 5 times. He throws a die and reports that it is 4. Find the probability that it is actually a 4.
28. A die is thrown three times. Events A and B are defined as below:
A: 5 on the first and 6 on the second throw. **B:** 3 or 4 on the third throw. Find the probability of B, given that A has already occurred.
29. A and B throw a die alternatively till one of them gets a number greater than four and wins the game. If A starts the game, what is the probability of B winning?
30. A black and a red die are rolled together. Find the conditional probability of obtaining the sum 8, given that the red die resulted in a number less than 4.

LONG ANSWER QUESTIONS (5 marks each)

31. Assume that the chances of a patient having a heart attack is 40 % . It is also assumed that a meditation and yoga course reduces the risk of heart attack by 30% and the prescription of a

certain drug reduces its chance by 25 % . At a time a patient can choose any one of the two options with equal probabilities. It is given that after going through one of the two options the patient selected at random suffers a heart attack. Find the probabilities that the patient followed a course of meditation and yoga.

- 32.** A Bag I contains 5 red and 4 white balls and a Bag II contains 3 red and 3 white balls. Two balls are transferred from the Bag I to the Bag II and then one ball is drawn from the Bag II. If the ball drawn from the Bag II is red, then find the probability that one red and one white ball are transferred from the Bag I to the Bag II.
- 33.** Out of group of 9 highly qualified doctors in a hospital, 6 are very kind and cooperative with their patients and so are very popular, while other three remain reserved. For a health camp, three doctors are selected at random. Find the mean variance and standard deviation of the number of very popular doctors.
- 34.** An insurance company insured 3000 scooterists, 4000 car drivers and 5000 motorbike drivers. The probabilities of an accident are 0.01, 0.03 and 0.15 respectively. One of the insured persons meets with accident. What is the probability that he is car driver?
- 35.** In a test, an examinee either guesses or copies or knows the answer to a multiple choice question with four choices. The probability that he makes a guess is $\frac{1}{3}$ and the probability that he copies the answer is $\frac{1}{6}$. The probability that his answer is correct, given that he copied it, is $\frac{1}{8}$. Find the probability that he knew the answer to the question, given that he correctly answered.
- 36.** There are three coins. One is a two – headed coin (having head on both faces), another is a biased coin that comes up heads 75% of the times and third is also a biased coin that comes up tails 40% of the times. One of the three coins is chosen at random and tossed, and it shows head. What is the probability that it was the two – headed coin?

ANSWERS

1. (i) 0.49 (ii) 24/49 2. (i) 2/5 (ii) 1/10 (iii) 17/30 (iv) 1/60 (v) 59/60
3. (i) 0.9 (ii) 0.01 (iii) 0.999 (iv) 0.083 (v) 0.01089 4. (a) 5. (a) 6. (a)
7. (a) 8. (a) 9. (d) 10. (c) 11. (b) 12. (c)
13. (c) 14. (c) 15. (c) 16. (d) 17. (b) 18. (d)
19. (d) 20. (c) 21. (i) $\frac{1}{10}$ (ii) $\frac{3}{10}$ 22. $\frac{1}{3}$
23. $P(A) = \frac{5}{6}$ and $P(B) = \frac{4}{5}$ OR : $P(A) = \frac{1}{5}$ and $P(B) = \frac{1}{6}$
24. $\frac{3}{5}$ 25. 38%, 62 % 26. 4 27. $\frac{3}{13}$ 28. $\frac{1}{3}$
29. $\frac{2}{5}$ 30. $\frac{1}{9}$ 31. $\frac{14}{29}$ 32. $\frac{20}{37}$ 33. $\frac{1}{2}, \frac{1}{\sqrt{2}}$ 34. $\frac{2}{15}$
35. $\frac{24}{29}$ 36. $\frac{20}{47}$

MATH (041) SQP BLUE PRINT

S.No.	CHAPTER	MCQ	A&R	2M	3M	5M	CS(4M)	WEI GH TA GE
1.	RELATIONS AND FUNCTIONS		1			1		8
2.	INVERSE TRIGONOMETRY			1				
3.	MATRICES	1						10
4.	DETERMINANTS	4				1		
5.	CONTINUITY AND DIFFERENTIABILITY	1		1				35
6.	APPLICATIONS OF DERIVATIVES		1	1			2	
7.	INTERGRALS	2			3			
8.	APPLICATIONS OF INTEGRALS					1		
9.	DIFFERETIAL EQUATIONS	2			1			
10.	VECTORS	3						14
11.	THREE DIMENSIONAL GEOMETRY	2		2		1		
12.	LINEAR PROGRAMMING PROBLE	2			1			5
13.	PROBABILITY	1			1		1	8
NUMBER OF QUESTIONS		18	2	5	6	4	3	38
TOTAL MARKS		18	2	10	18	20	12	80

KENDRIYA VIDYALAYA SANGATHAN, REGIONAL OFFICE, RAIPUR
Sample Paper -1 (2022-23)
Mathematics
Class - XII

TIME: 3 Hours

Maximum

Marks: 80

General Instructions:

1. This Question paper contains - five sections A, B, C, D and E. Each section is compulsory. However, there are internal choices in some questions.
2. **Section A** has 18 MCQ's and 02 Assertion-Reason based questions of 1 mark each.
3. **Section B** has 5 Very Short Answer (VSA)-type questions of 2 marks each.
4. **Section C** has 6 Short Answer (SA)-type questions of 3 marks each.
5. **Section D** has 4 Long Answer (LA)-type questions of 5 marks each.
6. **Section E** has 3 source based/case based/passage based/integrated units of assessment (4 marks each) with sub parts.

SECTION A

(Multiple Choice Questions)

Each question carries 1 mark

1. If the matrix $A = \begin{bmatrix} 0 & a & -3 \\ 2 & 0 & -1 \\ b & 1 & 0 \end{bmatrix}$ is skew symmetric, the values of 'a' and 'b' are
(a) $a = 2, b = 3$ (b) $a = -2, b = 3$ (c) $a = 2, b = -3$ (d) $a = 2, b = -3$
2. The value of x, if the matrix $\begin{bmatrix} 5-x & x+1 \\ 2 & 4 \end{bmatrix}$ is singular is
(a) -3 (b) 4 (c) 0 (d) 3
3. If $f(x) = \begin{cases} 1; & \text{if } x \leq 3 \\ ax + b; & \text{if } 3 < x < 5 \\ 7; & \text{if } 5 \leq x \end{cases}$, then the values of a and b so that f(x) is continuous is
(a) $a = 3, b = 3$ (b) $a = 3, b = 4$ (c) $a = 3, b = -8$ (d) None of these
4. Write the direction ratios of the line : $3x + 1 = 6y - 2 = 1 - z$
(a) 2,1,6 (b) 2,1,-6 (c) -2,-1,6 (d) 2,-1,-6
5. $\int \frac{dx}{e^x + e^{-x}}$ is equal to
(a) $\tan^{-1}(e^x) + c$ (b) $\tan^{-1}(e^{-x}) + c$ (c) $\log(e^x - e^{-x}) + c$
(d) $\log(e^x + e^{-x}) + c$

6. If $f(a + b - x) = f(x)$, then $\int_a^b xf(x)$ is equal to
- (a) $\frac{a+b}{2} \int_a^b f(b-x)dx$ (b) $\frac{a+b}{2} \int_a^b f(b+x)dx$
- (c) $\frac{b-a}{2} \int_a^b f(x)dx$ (d) $\frac{a+b}{2} \int_a^b f(x)dx$
7. If A is any square matrix of order 3×3 such that $|A| = 3$, then the value of $|\text{adj}A|$ is?
- (a) 3 (b) $\frac{1}{3}$ (c) 9 (d) 27
8. If $(2\hat{i} + 6\hat{j} + 27\hat{k}) \times (2\hat{i} + p\hat{j} + q\hat{k}) = \vec{0}$, then the values of p and q are?
- (a) $p=6, q=27$ (b) $p=3, q=\frac{27}{2}$ (c) $p=6, q=\frac{27}{2}$ (d) $p=3, q=27$
9. The point which does not lie in the half plane $2x + 3y - 12 \leq 0$ is
- (a) (1,2) (b) (2,1) (c) (2,3) (d) (-3,2)
10. An urn contains 6 balls of which two are red and four are black. Two balls are drawn at random. Probability that they are of the different colours is
- (a) $\frac{2}{5}$ (b) $\frac{1}{15}$ (c) $\frac{8}{15}$ (d) $\frac{4}{15}$
11. The equation of the line in the vector form passing through the point (-1,3,5) and parallel to the line $\frac{x-3}{2} = \frac{y-4}{3}, z = 2$ is
- (a) $\vec{r} = (-\hat{i} + 3\hat{j} + 5\hat{k}) + \lambda(2\hat{i} + 3\hat{j} + \hat{k})$
- (b) $\vec{r} = (-\hat{i} + 3\hat{j} + 5\hat{k}) + \lambda(2\hat{i} + 3\hat{j})$
- (c) $\vec{r} = (2\hat{i} + 3\hat{j} - 2\hat{k}) + \lambda(\hat{i} + 3\hat{j} + 5\hat{k})$
- (d) $\vec{r} = (2\hat{i} + 3\hat{j}) + \lambda(-\hat{i} + 3\hat{j} + 5\hat{k})$
12. The magnitude of the projection of vector $(2\hat{i} - \hat{j} + \hat{k})$ on vector $(\hat{i} - 2\hat{j} + 2\hat{k})$ is
- (a) 2 Unit (b) 3 Unit (c) 5 Unit (d) 4 Unit
13. The general solution of the differential equation $ydx - xdy = 0$ is
- (a) $xy = c$ (b) $x = cy^2$ (c) $y = cx$ (d) $y = cx^2$
14. The corner point of the feasible region for an LPP are (0,2)(3,0)(6,0)(6,8) and (0,5). The minimum value of objective function for $z = 4x + 6y$ occurs at
- (a) (0,2) only
- (b) (3,0) only
- (c) Any point on the line segment joining the point (0,2) and (3,0)

(d) The mid point of the line segment (0,2) and (3,0)

15. If $A = \begin{bmatrix} 1 & -2 & 3 \\ -4 & 2 & 5 \end{bmatrix}$ and $B = \begin{bmatrix} 2 & 3 \\ 4 & 5 \\ 2 & 1 \end{bmatrix}$ and $BA = [b_{ij}]$, find $b_{21} + b_{32}$.

- (a) -14 (b) 14 (c) 18 (d) -18

16. If $\begin{vmatrix} 3 & x \\ x & 1 \end{vmatrix} = \begin{vmatrix} 3 & 2 \\ 4 & 1 \end{vmatrix}$, find x .

- (a) $\pm 2\sqrt{2}$ (b) 8 (c) $\sqrt{2}$ (d) 2

17. Find the area of parallelogram, whose adjacent sides are determined by the vectors $\vec{a} = \hat{i} - 2\hat{j} + 3\hat{k}$, $\vec{b} = 2\hat{i} + \hat{j} - 4\hat{k}$

- (a) $6\sqrt{5}$ sq. unit (b) $5\sqrt{6}$ sq. unit (c) 100 sq. unit (d) 25 sq. unit

18. Find the order and degree of the differential equation $y = x \frac{dy}{dx} + \sqrt{a^2 \left(\frac{dy}{dx}\right)^2 + b^2}$

- (a) order = 1, degree = 1 (b) order = 1, degree = 2 (c) order = 2, degree = 2 (d) order = 2, degree = 1

In the following questions, a statement assertion (A) is followed by a statement of Reason (R). Choose the correct answer out of the following choices.

- A. Both A and R are true and R is the correct explanation of A.
- B. Both A and R are true, but R is not the correct explanation of A.
- C. A is true, but R is false.
- D. A is false, but R is true.

19. Assertion: A relation $R = \{(1,1)(1,3) (3,1) (3,3) (3,5)\}$ defined on set $A = \{1,3,5\}$ is reflexive.

Reason: A relation R on the set A is said to be transitive if for $(a, b) \in R$ and $(b, c) \in R$ we have $(a, c) \in R$.

20. Assertion: The function $[x(x - 2)]^2$ is increasing in $(0,1) \cup (2, \infty)$

Reason: $\frac{dy}{dx} = 0$ when $x = 0, 1, 2$

SECTION B

This Section Comprises of very short answer type questions (VSA) of 2 marks each .

21. If $|\vec{a}| = 13$, $|\vec{b}| = 5$ and $\vec{a} \cdot \vec{b} = 60$, then find $|\vec{a} \times \vec{b}|$.

OR

If $|\vec{a} \times \vec{b}|^2 + |\vec{a} \cdot \vec{b}|^2 = 400$ and $|\vec{a}| = 5$, then write the value of $|\vec{b}|$.

22. Find the vector equation of the line joining the points whose position vectors are $2\hat{i} - \hat{j} + \hat{k}$ and $\hat{i} + 2\hat{j} - 3\hat{k}$.

23. Find the value of $\tan^{-1} \sqrt{3} - \cot^{-1} (-\sqrt{3})$

24. Prove that the function $f(x) = x^3 - 6x^2 + 13x - 18$ is increasing on R.

25. Prove that $f(x) = \frac{4 \sin x}{2 + \cos x} - x$ is an increasing function of x in $\left[0, \frac{\pi}{2}\right]$.

OR

Find the value of k so that the following function f is continuous at $x = \frac{\pi}{2}$

$$f(x) = \begin{cases} \frac{k \cos x}{\pi - 2x}, & \text{if } x \neq \frac{\pi}{2} \\ 5, & \text{if } x = \frac{\pi}{2} \end{cases}$$

SECTION C

This Section Comprises of short answer type questions (SA) of 3 marks each .

26. Evaluate: $\int_0^{\frac{1}{\sqrt{2}}} \frac{\sin^{-1} x}{(1-x^2)^{\frac{3}{2}}} dx$

27. Find : $\int \frac{x}{(x^2+1)(x-1)} dx$.

OR

Find: $\int \left(\frac{1+\sin x}{1+\cos x}\right) e^x dx$.

28. Solve the differential equation: $\left[x \sin^2 \left(\frac{y}{x}\right) - y\right] dx + x dy = 0$, given $y = \frac{\pi}{4}$ when $x = 1$.

OR

Solve the differential equation $\frac{dy}{dx} - y = \sin x$

29. There are three coins. First is a biased that comes up tails 60 % of the times, second is also a biased coin that comes up heads 75% of the times and third is an unbiased coin. One of the three coins is chosen at random and tossed, it shows head, what is the probability that it was the first coin?

30. Evaluate: $\int \frac{(x^4-x)^{\frac{1}{4}}}{x^5} dx$

OR

Evaluate: $\int \frac{dx}{5-8x-x^2}$

31. Maximize: $Z = x + 2y$, subject to the constraints:

$$x + 2y \geq 100$$

$$2x - y \leq 0$$

$$2x + y \leq 200$$

$$x, y \geq 0$$

Solve the above LPP graphically.

SECTION D

This Section Comprises of Long answer type questions (LA) of 5 marks each .

32. Use the product $\begin{bmatrix} 1 & -1 & 2 \\ 0 & 2 & -3 \\ 3 & -2 & 4 \end{bmatrix} \begin{bmatrix} -2 & 0 & 1 \\ 9 & 2 & -3 \\ 6 & 1 & -2 \end{bmatrix}$ to solve the system of equations:

$$x - y + 2z = 1$$

$$2y - 3z = 1$$

$$3x - 2y + 4z = 2$$

OR

Solve the following system of linear equations by matrix method, where $x, y, z \neq 0$

$$\frac{2}{x} - \frac{3}{y} + \frac{3}{z} = 10$$

$$\frac{1}{x} + \frac{1}{y} + \frac{1}{z} = 10$$

$$\frac{3}{x} - \frac{1}{y} + \frac{2}{z} = 13$$

33. Using integration, find the area of the region bounded between the parabola $4y = 3x^2$ and the line $2y = 3x + 12$.

OR

Find the area bounded by the ellipse $4x^2 + 9y^2 = 36$.

34. Find the shortest distance between the lines whose vector equations are

$$\vec{r} = (1 - t)\hat{i} + (t - 2)\hat{j} + (3 - 2t)\hat{k} \quad \text{and} \quad \vec{r} = (s + 1)\hat{i} + (2s - 1)\hat{j} - (2s + 1)\hat{k}$$

35. Show that the relation R in the set R of real numbers, defined as

$$R = \{(a, b) : a \leq b^2\}$$
 is neither reflexive nor symmetric nor transitive.

SECTION E

(This section comprises of 3 Case- Study /Passage –Based questions of 4 Marks each with two Sub-parts. First two case study questions have 3 sub-parts (i),(ii), (iii) of marks 1,1,2 respectively . The 3rd case study question have two sub parts of 2 marks each .)

36. **Case Study -1** : Read the following and answer the questions given below

The front gate of a building is in the shape of a trapezium as shown below. Its three sides other than base are of 10 m each. The height of the gate is h meter. On the basis of below figure, answer the following questions:

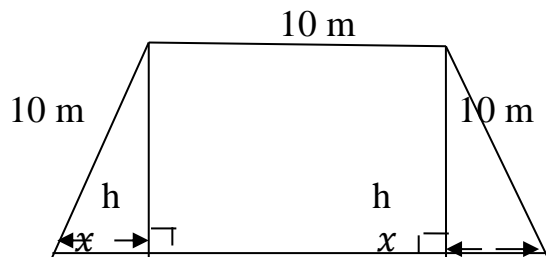

- Write the Area (A) of the gate in terms of x .
- Write the value of x when Area (A) is maximum, .
- Write the value of h when Area (A) is maximum, .

OR

Write the Maximum value of Area (A) .

37. **Case Study -2** : Read the following and answer the questions given below

Given three identical boxes 1st, 2nd and 3rd each containing two coins. In 1st box both coins are gold coins, in 2nd box both are silver coins and in 3rd box there is one gold and one silver coin. A person chooses a box at random and takes out a coin.

On the basis of above information, answer the following questions:

- What is the probability of choosing 1st box ?
- What is the probability of getting gold coin from 3rd box ?
- What is the total probability of drawing gold coin ?

OR

If drawn coin is of gold the probability that other coin in the box is also of gold ?

38. Case Study -2 : Read the following and answer the questions given below

Sand is pouring from a pipe at the rate of $12 \text{ cm}^3 / \text{second}$ the falling sand forms a cone on the ground in such a way that the height of the cone is always $1/6^{\text{th}}$ of the radius of the base . Based on above information answer the following :

- (i) Write the expression for volume in terms of height only.
- (ii) What is the rate of Change of height, when height is 4 cm?

Note : All alternative solutions are to be accepted at par.

Q. NOS.	VALUE- POINTS	MARKS
1.	C	1
2.	D	1
3.	C	1
4.	B	1
5.	A	1
6.	B	1
7.	C	1
8.	B	1
9.	C	1
10.	C	1
11.	A	1
12.	A	1
13.	C	1
14.	C	1
15.	D	1
16.	A	1
17.	B	1
18.	B	1
19.	D	1
20.	b	1
21.	$\cos \theta = \frac{\vec{a} \cdot \vec{b}}{ \vec{a} \vec{b} } = \frac{60}{13 \times 5} = \frac{12}{13} ; \sin \theta = \frac{5}{13} ; \vec{a} \times \vec{b} = \vec{a} \vec{b} \sin \theta = 13 \times 5 \times \frac{5}{13} = 25$ OR $(\vec{a} \vec{b} \sin \theta)^2 + (\vec{a} \vec{b} \cos \theta)^2 = 400 \Rightarrow \vec{a} ^2 \vec{b} ^2 = 400$ $\Rightarrow \vec{b} ^2 = 16 \Rightarrow \vec{b} = 4$	$1 + \frac{1}{2} + \frac{1}{2}$ 1 1
22.	$\vec{a} = 2\hat{i} - \hat{j} + \hat{k}$ and $\vec{b} = \hat{i} + 2\hat{j} - 3\hat{k}$. ; $\vec{b} - \vec{a} = -\hat{i} + 3\hat{j} - 4\hat{k}$; vector equation of the line is: $\vec{r} = \vec{a} + \lambda(\vec{b} - \vec{a}) \Rightarrow \vec{r} = 2\hat{i} - \hat{j} + \hat{k} + \lambda(-\hat{i} + 3\hat{j} - 4\hat{k})$. (answer)	$1 + \frac{1}{2}$ $+\frac{1}{2}$
23.	$\tan^{-1} \sqrt{3} = \frac{\pi}{3}$, $\cot^{-1}(-\sqrt{3}) = 5\pi/6$ $\frac{\pi}{3} - 5\pi/6 = -\pi/2$	1 1

24	$f(x) = x^3 - 6x^2 + 13x - 18$; $f'(x) = 3x^2 - 12x + 13$; $f''(x) = 3x^2 - 12x + 12 + 1$; $f''(x) = 3(x^2 - 4x + 4) + 1$; $f''(x) = 3(x - 2)^2 + 1$ Here $3(x - 2)^2 \geq 0$ Clearly $3(x - 2)^2 + 1 > 0$; So $f'(x) > 0 \forall x \in R$. Therefore f is increasing function on R.	$\frac{1}{2} + \frac{1}{2}$ $+ \frac{1}{2} + \frac{1}{2}$
25.	$f'(x) = \frac{\cos x (4 - \cos x)}{(2 + \cos x)^2}$ For all $x \in \left(0, \frac{\pi}{2}\right)$, $f'(x) > 0$ and hence f is increasing in $\left[0, \frac{\pi}{2}\right]$.	1 1
OR	$\lim_{x \rightarrow \frac{\pi}{2}} f(x) = 5 \Rightarrow \lim_{x \rightarrow \frac{\pi}{2}} \left(\frac{k \cos x}{\pi - 2x}\right) = 5$ $\Rightarrow k = 10$	1 1
26.	Put $\sin^{-1}x = \theta$, $x = \sin\theta$. $x = 0, \theta = 0, x = \frac{1}{\sqrt{2}}, \theta = \frac{\pi}{4}$ $dx = d\theta$; $I = \int_0^{\frac{\pi}{4}} \theta \cdot \sec^2\theta d\theta$, $= [\theta \cdot \tan\theta - \int 1 \cdot \tan\theta d\theta] \Rightarrow \theta \cdot \tan\theta - \log \sec\theta $; $I = [\theta \cdot \tan\theta]_0^{\frac{\pi}{4}} - [\log \sec\theta]_0^{\frac{\pi}{4}} =$ $\frac{\pi}{4} - \frac{1}{2} \log 2$ Ans: $\frac{\pi}{4} - \frac{1}{2} \log 2$	1 1 1
27.	$\frac{x}{(x^2+1)(x-1)} = \frac{Ax+B}{x^2+1} + \frac{C}{x-1}$; $x = (Ax + B)(x - 1) + C(x^2 + 1)$; $A = -\frac{1}{2}, B =$ $\frac{1}{2}, C = \frac{1}{2}$; $I = -\frac{1}{2} \int \frac{x}{(x^2+1)} dx + \frac{1}{2} \int \frac{1}{(x^2+1)} dx + \frac{1}{2} \int \frac{1}{(x-1)} dx$; Ans: $\log \left \frac{1}{1+x^2} \right +$ $\frac{1}{2} \tan^{-1}x + \frac{1}{2} \log x - 1 + c$	1 + 1 1
OR	$\int \left(\frac{1 + \sin x}{1 + \cos x}\right) e^x dx = \int \left(\frac{1}{2} \sec^2 \frac{x}{2} + \tan \frac{x}{2}\right) e^x dx$ $= e^x \tan \frac{x}{2} + c$	2 1
28.	$\frac{dy}{dx} = \frac{y - x \sin^2 \frac{y}{x}}{x}$; Put $y = vx \therefore \frac{dy}{dx} = v + x \frac{dv}{dx} \therefore v + x \frac{dv}{dx} = \frac{vx - x \sin^2 v}{x}$; $x \frac{dv}{dx} =$ $-\sin^2 v$; $\int \frac{dv}{\sin^2 v} = -\int \frac{1}{x} dx$; $-\cot v = -\log x + c$; $-\cot \frac{y}{x} = -\log x + c$ given $y = \frac{\pi}{4}$ when $x = 1 \Rightarrow c = -1$; $-\cot \frac{y}{x} = -\log x - 1$; $\cot \frac{y}{x} = \log x + 1$ Therefore $\cot \frac{y}{x} = \log x \cdot e$ (answer)	1 1 1
OR	Given differential equation $\frac{dy}{dx} - y = \sin x \Rightarrow I.F. = e^{-x}$ Solution is given by $y \cdot e^{-x} = \int \sin x \cdot e^{-x} dx$ On solving $y = -\frac{1}{2}(\sin x - \cos x) + ce^x$	1 1 2 1 2
29.	Dfined the events : E_1 : I coin is selected E_2 : II coin is selected, : E_3 : III coin is selected , A : Selcted coin tassed and shows Head; Required $P(E_1/A) = ?$ Now $P(E_1) = P(E_2) = P(E_3) = \frac{1}{3}$ and $P(A/E_1) = \frac{40}{100}$, $P(A/E_2) = \frac{75}{100}$, $P(A/E_3) =$ $\frac{1}{2} = \frac{50}{100}$, $P(E_1/A) = \frac{P(E_1) \cdot P(A/E_1)}{P(E_1) \cdot P(A/E_1) + P(E_2) \cdot P(A/E_2) + P(E_3) \cdot P(A/E_3)}$. $P(E_1/A) = \frac{\frac{1}{3} \times \frac{40}{100}}{\frac{1}{3} \times \frac{40}{100} + \frac{1}{3} \times \frac{75}{100} + \frac{1}{3} \times \frac{50}{100}} = \frac{40}{40 + 75 + 50} = \frac{40}{165} = \frac{8}{33}$ (ANSWER)	1 1 1
30.	$\int \frac{(x^4 - x)^{\frac{1}{4}}}{x^5} dx = \int \frac{\left(1 - \frac{1}{x^3}\right)^{\frac{1}{4}}}{x^4} dx$	1 1 1

	<p>Put $1 - \frac{1}{x^3} = t$ i.e., $\frac{1}{x^4} dx = \frac{dt}{3}$</p> $\int \frac{(x^4 - x)^{\frac{1}{4}}}{x^5} dx = \frac{1}{3} \int t^{\frac{1}{4}} dt = \frac{4}{15} \left(1 - \frac{1}{x^3}\right)^{\frac{5}{4}} + c$ <p style="text-align: center;">OR</p> $\int \frac{dx}{5-8x-x^2} = \int \frac{1}{(\sqrt{21})^2 - (x+4)^2} dx = \frac{1}{2\sqrt{21}} \log \left \frac{\sqrt{21}+(x+4)}{\sqrt{21}-(x+4)} \right + c$	2+1
31.	<p>For correct lines and shading of feasible region</p> <p>Finding corner points of feasible region and evaluating Z at corner points</p> <p>Writing the maximum value of Z and the corresponding point.</p>	1 1 1
32.	$\begin{bmatrix} 1 & -1 & 2 \\ 0 & 2 & -3 \\ 3 & -2 & 4 \end{bmatrix} \begin{bmatrix} -2 & 0 & 1 \\ 9 & 2 & -3 \\ 6 & 1 & -2 \end{bmatrix} = I$ $\Rightarrow \begin{bmatrix} 1 & -1 & 2 \\ 0 & 2 & -3 \\ 3 & -2 & 4 \end{bmatrix}^{-1} = \begin{bmatrix} -2 & 0 & 1 \\ 9 & 2 & -3 \\ 6 & 1 & -2 \end{bmatrix}$ $\begin{bmatrix} 1 & -1 & 2 \\ 0 & 2 & -3 \\ 3 & -2 & 4 \end{bmatrix} \begin{bmatrix} x \\ y \\ z \end{bmatrix} = \begin{bmatrix} 1 \\ 1 \\ 2 \end{bmatrix}$ $\Rightarrow \begin{bmatrix} x \\ y \\ z \end{bmatrix} = \begin{bmatrix} -2 & 0 & 1 \\ 9 & 2 & -3 \\ 6 & 1 & -2 \end{bmatrix} \begin{bmatrix} 1 \\ 1 \\ 2 \end{bmatrix} = \begin{bmatrix} 0 \\ 5 \\ 3 \end{bmatrix}$ <p>Therefore, $x = 0, y = 5, z = 3$</p> <p style="text-align: center;">OR</p> $A = \begin{bmatrix} 2 & -3 & 3 \\ 1 & 1 & 1 \\ 3 & -1 & 2 \end{bmatrix}, \quad X = \begin{bmatrix} 1/x \\ 1/y \\ 1/z \end{bmatrix}, \quad B = \begin{bmatrix} 10 \\ 10 \\ 13 \end{bmatrix}$ <p>$A = -9$</p> $A^{-1} = -\frac{1}{9} \begin{bmatrix} 3 & 3 & -6 \\ 1 & -5 & 1 \\ -4 & -7 & 5 \end{bmatrix}$ $X = \begin{bmatrix} 1/x \\ 1/y \\ 1/z \end{bmatrix} = -\frac{1}{9} \begin{bmatrix} 3 & 3 & -6 \\ 1 & -5 & 1 \\ -4 & -7 & 5 \end{bmatrix} \begin{bmatrix} 10 \\ 10 \\ 13 \end{bmatrix}$ $\Rightarrow \begin{bmatrix} 1/x \\ 1/y \\ 1/z \end{bmatrix} = \begin{bmatrix} 2 \\ 3 \\ 5 \end{bmatrix} \quad \text{Hence, } x = \frac{1}{2}, y = \frac{1}{3} \text{ and } z = \frac{1}{5}$	1 1 1 2 1 2 2

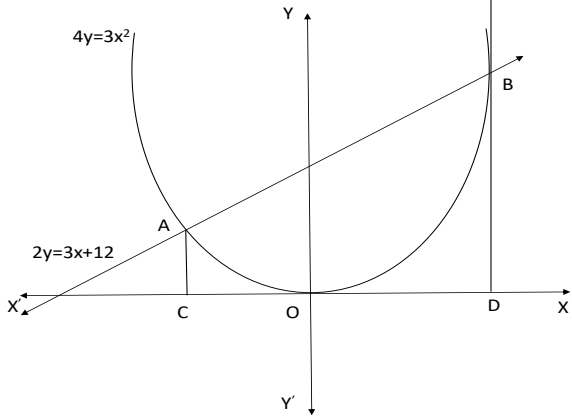
33.	 <p>Area (AOBA) = ar (ACDBA) – ar(ACO) – ar(ODBO)</p> <p>Now ar (ACDBA) = $\frac{1}{2} \int_{-2}^4 (3x + 12) dx = \frac{1}{2} \left[\frac{3x^2}{2} + 12x \right]_{-2}^4 = 45$ and ar(ACO) + ar(ODBO) = $\frac{3}{4} \int_{-2}^4 x^2 dx = \frac{1}{4} [x^3]_{-2}^4 = 18$ Therefore Area (AOBA) = 45 – 18 = 27 sq units Ans: 27 sq units</p>	2
OR	<p>To draw the correct graph and writing the equation in standard form</p> <p>Required area = $4 \int_0^3 \frac{\sqrt{36-4x^2}}{3} dx = 6\pi$</p>	1 2 2
34.	<p>In vector form, lines are $\vec{r} = \hat{i} - 2\hat{j} + 3\hat{k} + t(-\hat{i} + \hat{j} - 2\hat{k})$ and $\vec{r} = \hat{i} - \hat{j} - \hat{k} + s(\hat{i} + 2\hat{j} - 2\hat{k})$ $\vec{a}_1 = \hat{i} - 2\hat{j} + 3\hat{k}, \vec{b}_1 = -\hat{i} + \hat{j} - 2\hat{k}, \vec{a}_2 = \hat{i} - \hat{j} - \hat{k}, \vec{b}_2 = \hat{i} + 2\hat{j} - 2\hat{k}$ $\vec{a}_2 - \vec{a}_1 = \hat{j} - 4\hat{k}$ $\vec{b}_1 \times \vec{b}_2 = 2\hat{i} - 4\hat{j} - 3\hat{k}$ and $\vec{b}_1 \times \vec{b}_2 = \sqrt{29}$ $d = \frac{ (\vec{a}_2 - \vec{a}_1) \cdot (\vec{b}_1 \times \vec{b}_2) }{ \vec{b}_1 \times \vec{b}_2 } = \frac{8}{\sqrt{29}}$</p>	1 1 1 1+1
35.	<p>For Reflexive with Example For Symmetric With Example For Transitive with Example</p>	1 2 2
36.	<p>(i) $(10 + x)\sqrt{100 - x^2}$ (ii) 5 m (iii) $5\sqrt{3}$ m OR $\frac{75\sqrt{3}}{2} \text{ m}^2$</p>	1 1 2
37.	<p>(i) $\frac{1}{3}$ (ii) $\frac{1}{2}$ (iii) $\frac{1}{2}$ Or $\frac{2}{3}$</p>	1 1 2
38.	<p>(i) $12\pi h^3$ (ii) $\frac{1}{48} \text{ cm/s}$</p>	2 2

XII
Session 2022-23
Mathematics (Code-041)

Time Allowed: 3 Hours

Maximum Marks: 80

General Instructions :

1. This Question paper contains - **five sections** A, B, C, D and E. Each section is compulsory. However, there are internal choices in some questions.
2. **Section A** has 18 **MCQ's** and **02** Assertion-Reason based questions of 1 mark each.
3. **Section B** has 5 **Very Short Answer (VSA)-type** questions of 2 marks each.
4. **Section C** has 6 **Short Answer (SA)-type** questions of 3 marks each.
5. **Section D** has 4 **Long Answer (LA)-type** questions of 5 marks each.
6. **Section E** has 3 **source based/case based/passage based/integrated units of assessment** (4 marks each) with sub parts.

SECTION A
(Multiple Choice Questions)
Each question carries 1 mark

1	If A and B are symmetric matrices of same order, then AB-BA is a (a) Skew-symmetric matrix (b) Symmetric matrix (c) Zero matrix (d) Identity
2	If $A = \begin{bmatrix} 3 & -2 \\ 4 & -2 \end{bmatrix}$, then the value of k if, $A^2 = kA - 2I$ is (a) 0 (b) 8 (c) -7 (d) 1
3	The area of a triangle with vertices A, B, C is given by (a) $\frac{1}{2} \vec{AB} \times \vec{AC} $ (b) $\frac{3}{4} \vec{AB} \times \vec{AC} $ (b) $ \vec{AC} \times \vec{AB} $ (d) $\frac{1}{2} \vec{AC} \times \vec{AB} $
4	. The function $f(x) = e^{ x }$ is (a) Continuous everywhere but not differentiable at x=0 (b) Continuous and differentiable everywhere (c) Not continuous at x=0 (d) None of the above
5	Find the antiderivative F of function defined by $f(x) = 4x^3 - 6$, where $F(0) = 3$. (a) $4x^4 - 6x + 3$ (b) $x^4 - 6x$ (c) $x^4 - 6x + 3$ (d) $x^4 - 6x - 3$
6	Find order and degree of the differential equation: $x^2 \frac{d^2y}{dx^2} = \left\{ 1 + \left(\frac{dy}{dx} \right)^2 \right\}^4$ (a) Order 2 Degree 1 (b) Order 1 Degree 2 (c) Order 4 Degree 1 (d) Order 1 Degree 4

7	<p>The solution set of the inequality $3x + 5y < 4$ is</p> <p>(a) an open half-plane not containing the origin. (b) an open half-plane containing the origin. (c) the whole XY-plane not containing the line $3x + 5y = 4$. (d) a closed half plane containing the origin.</p>
8	<p>The projection of the vector $3\hat{i} - \hat{j} - 2\hat{k}$ on the vector $\hat{i} + 2\hat{j} - 3\hat{k}$ is</p> <p>(a) $\frac{7}{14}$ (b) $\frac{7}{\sqrt{14}}$ (c) $\frac{6}{13}$ (d) $\frac{7}{2}$</p>
9	<p>$\int_0^1 x(1-x)^4 dx =$</p> <p>(a) $\frac{1}{20}$ (b) $\frac{1}{25}$ (c) $\frac{1}{30}$ (d) $\frac{1}{40}$</p>
10	<p>If A and B are invertible matrices, then which of the following is not correct?</p> <p>(a) $\text{adj } A = A \cdot A^{-1}$ (b) $\det(A^{-1}) = (\det(A))^{-1}$ (c) $(AB)^{-1} = B^{-1}A^{-1}$ (d) $(A+B)^{-1} = B^{-1} + A^{-1}$</p>
11	<p>The corner points of the shaded unbounded feasible region of an LPP are (0, 4), (0.6, 1.6) and (3, 0) as shown in the figure. The minimum value of the objective function $Z = 4x + 6y$ occurs</p> <p>At</p> <p>(a) (0.6, 1.6) only (b) (3, 0) only (c) (0.6, 1.6) and (3, 0) only (d) at every point of the line-segment joining the points (0.6, 1.6) and (3, 0)</p>
12	<p>The area of a triangle with vertices $(-3,0)$, $(3,0)$ and $(0,k)$ is 9 sq. units. Then, the value of k will be</p> <p>(a) 9 (b) 3 (c) -9 (d) 6</p>
13	<p>Adjoint of matrix $\begin{bmatrix} 1 & 2 \\ 3 & 4 \end{bmatrix}$ is</p> <p>(a) $\begin{bmatrix} 4 & 2 \\ 3 & 1 \end{bmatrix}$ (b) $\begin{bmatrix} 4 & -2 \\ -3 & 1 \end{bmatrix}$ (c) $\begin{bmatrix} 1 & 2 \\ 3 & 4 \end{bmatrix}$ (d) $\begin{bmatrix} 1 & -2 \\ -3 & 4 \end{bmatrix}$</p>
14	<p>Let E and F be events with $P(E) = 3/5$, $P(F) = 3/10$ and $P(E \cap F) = 1/5$, then</p> <p>(a) E and F are independent (b) E and F are dependent</p>

	(c) can't be determined (d) none of them
15	Find the equation of the curve passing through the point (1, 1) whose differential equation is $x dy = (2x^2 + 1) dx$ ($x \neq 0$) (a) $y = x^2 + \log x$ (b) $y = x + \log x^2$ (c) $y = x^2 - \log x$ (d) $y = x - \log x$
16	If $y = \log \sqrt{\tan x}$, then $\frac{dy}{dx}$ is (A) $\cos 2x$ (B) $\sin 2x$ (C) $\operatorname{cosec} 2x$ (D) none of these
17	If a is a nonzero vector of magnitude 'a' and λ a nonzero scalar, then λa is unit vector if (A) $\lambda = 1$ (B) $\lambda = -1$ (C) $a = \lambda $ (D) $a = 1/ \lambda $
18	P is a point on the line joining the points $(0, 5, -2)$ and $B(3, -1, 2)$. If the x-coordinate of P is 6, then its z-coordinate is (a) 10 (b) 6 (c) -6 (d) -10

ASSERTION REASON

In the following questions, a statement of assertion (A) is followed by a statement of Reason (R). Choose the correct answer out of the following choices.

- (a) Both A and R are true and R is the correct explanation of A.
 (b) Both A and R are true but R is not the correct explanation of A.
 (c) A is true but R is false.
 (d) A is false but R is true.

19	Assertion (A) Range of $\sin^{-1} x$ is $\left[-\frac{\pi}{2}, \frac{\pi}{2}\right]$ Reason (R) The principal value of $\sin^{-1} \frac{1}{2} = \frac{\pi}{6}$
20	Assertion (A): The acute angle between the line $\vec{r} = \hat{i} + \hat{j} + 2\hat{k} + \lambda(\hat{i} - \hat{j})$ and the x-axis is 45° Reason (R): The acute angle θ between the lines $\vec{r} = x_1\hat{i} + y_1\hat{j} + z_1\hat{k} + \lambda(a_1\hat{i} + b_1\hat{j} + c_1\hat{k})$ and $\vec{r} = x_2\hat{i} + y_2\hat{j} + z_2\hat{k} + \mu(a_2\hat{i} + b_2\hat{j} + c_2\hat{k})$ is given by $\cos \theta = \frac{a_1a_2 + b_1b_2 + c_1c_2}{\sqrt{a_1^2 + b_1^2 + c_1^2} \sqrt{a_2^2 + b_2^2 + c_2^2}}$

SECTION B

This section comprises of very short answer type-questions (VSA) of 2 marks each

21	Find the value of $\sin (\tan^{-1} (0.75))$ Or If N be the set of all-natural numbers, consider $f: N \rightarrow N$ such that $f(x) = 2x, \forall x \in N$, then show that f is one-one but not onto.
22	A stone is dropped into a quiet lake and waves move in circles at a speed of 4cm per second. At the instant, when the radius of the circular wave is 10 cm, how fast is the enclosed area increasing?
23	Show that the points A (1, 2, 7), B (2, 6, 3) and C (3, 10, -1) are collinear. OR Find the coordinates of the point where the line through (5, 1, 6) and (3, 4, 1) crosses the YZ-plane.
24	If $y = 3 \cos (\log x) + 4 \sin (\log x)$, show that $x^2 y_2 + xy_1 + y = 0$
25	Find the magnitude of two vectors, having the same magnitude and such that the angle between them is 60° and their scalar product is $\frac{1}{2}$

SECTION C

(This section comprises of short answer type questions (SA) of 3 marks each)

26	Find $\int \frac{x^2+1}{x^2-5x+6} dx$
27	A box of oranges is inspected by examining three randomly selected oranges drawn without replacement. If all the three oranges are good, the box is approved for sale, otherwise, it is rejected. Find the probability that a box containing 15 oranges out of which 12 are good and 3 are bad ones will be approved for sale OR A coin is biased so that the head is 3 times as likely to occur as tail. If the coin is tossed twice, find the probability distribution of number of tails.
28	Evaluate: $\int_0^{\frac{\pi}{2}} \sqrt{\sin \theta} \cdot \cos^5 \theta d\theta$ OR Evaluate: $\int_0^1 x(1-x)^n dx$
29	Show that the differential equation $(x - y) dy/dx = x + 2y$ is homogeneous and solve it. OR Solve: $x^2 \frac{dy}{dx} = x^2 - 2y^2 + xy$
30	Solve the following Linear Programming Problem graphically: Maximize $Z = 400x + 300y$ subject to $x + y \leq 200, x \leq 40, x \geq 20, y \geq 0$

31	Evaluate: $\int \frac{x^2}{(x^2+1)(x^2+4)} dx$
----	--

SECTION D (LONG ANSWER TYPE) (5 MARKS EACH)

32	Make a rough sketch of the region $\{(x, y): 0 \leq y \leq x^2, 0 \leq y \leq x, 0 \leq x \leq 2\}$ and find the area of the region using integration.
33	Show that the relation R defined in the set A of all polygons as $R = \{(P1, P2) : P1 \text{ and } P2 \text{ have same number of sides}\}$, is an equivalence relation. What is the set of all elements in A related to the right-angle triangle T with sides 3, 4 and 5? OR If R1 and R2 are equivalence relations in a set A, show that $R1 \cap R2$ is also an equivalence relation.
34	An insect is crawling along the line $\vec{r} = 6i + 2j + 2\hat{k} + (i - 2j + 2\hat{k})$ and another insect is crawling along the line $\vec{r} = -4i - \hat{k} + (3i - 2j - 2\hat{k})$. At what points on the lines should they reach so that the distance between them is the shortest? Find the shortest possible distance between them.
35	Solve the system of equations by using matrix method: $2x - 3y + 5z = 11$ $3x + 2y - 4z = -5$ $x + y - 2z = -3$

SECTION E (CASE BASED QUESTIONS) (This section comprises of 3 case-study/passage-based questions of 4 marks each with two sub-parts. First two case study questions have three sub-parts (i), (ii), (iii)of marks 1, 1, 2 respectively. The third case study question has two sub-parts of 2 marks each.)

36	Shape of a toy is given as $f(x) = 6(2x^4 - x^2)$. To make the toy beautiful 2 sticks which are perpendicular to each other were placed at a point (2,3), above the toy. <ol style="list-style-type: none">1. Which value from the following may be abscissa of critical point?2. Find the second order derivative of the function at $x = 5$.3. At which of the following intervals will $f(x)$ be increasing?
37	$P(x) = -5x^2 + 125x + 37500$ is the total profit function of acompany, where x is the production of the company. <ol style="list-style-type: none">1. What will be the production when the profit is maximum?2. What will be the maximum profit? Check in which interval the profit is strictly increasing. When the x value lies between (2,3) then the function is



There are two anti-aircraft guns, named as A and B. The probabilities that the shell fired from them hits an airplane are 0.3 and 0.2 respectively. Both of them fired one shell at an airplane at the same time.

- (i) What is the probability that the shell fired from exactly one of them hit the plane?
- (ii) If it is known that the shell fired from exactly one of them hit the plane, then what is the probability that it was fired from B?

1	(b) Symmetric matrix	
2	(d) 1	
3	$1/2 \vec{AB} \times \vec{AC} $	
4	(a) Continuous everywhere but not differentiable at $x=0$	
5	(c) $x^4 - 6x + 3$	
6	(a) Order 2 Degree 1	
7	(b) an open half-plane containing the origin	
8	(b) $\frac{7}{\sqrt{14}}$	
9	(c) $\frac{1}{30}$	
10	(d) $(A + B)^{-1} = B^{-1} + A^{-1}$	
11	(d) at every point of the line-segment joining the points (0.6, 1.6) and (3, 0)	
12	(b) 3	
13	(b) $\begin{bmatrix} 4 & -2 \\ -3 & 1 \end{bmatrix}$	
14	(b) E and F are dependent	
15	(a) $y = x^2 + \log x$	
16	(C) Cosec 2x	
17	(D) $a = 1/ \lambda $	
18	(b) 6	
19	(e) Both A and R are true but R is not the correct explanation of A.	
20	(a) Both A and R are true and R is the correct explanation of A.	
21	Ans : 3/5 OR One-one onto	1 1
22	$A = \pi r^2$ $dA/dt = 2\pi r dr/dt$ $dA/dt = 2\pi r (4) = 8\pi r$ $(dA/dt) = 80\pi \text{ cm}^2/\text{sec}$	0.5 0.5 0.5 0.5
23	DR OF AB $\langle 1, 4, 4 \rangle$ DR OF BC $\langle 1, 4, 4 \rangle$ Eq of line through (5,1,6) and (3,4,1) Put $x=0$ Coordinate of point (0, -13/2, 7/2)	1 1 1 0.5 0.5
24	Correct y_1 and y_2 Establish the equation	1 1
25	$\vec{a} \cdot \vec{a} = \frac{1}{2}$ $ \vec{a} \cdot \vec{a} \cos 60^\circ = \frac{1}{2}$ $ \vec{a} = 1$	0.5 0.5 1
26	$\int \frac{x^2+1}{x^2-5x+6} dx = \int dx + \int \frac{5(x-1)}{x^2-5x+6} dx$ <i>partial fraction</i>	1 1

	$x - 5 \log x - 2 + 10 \log x - 3 + C$	1														
27	$C(12, 3)/C(15, 2) = 12.11.10/15.14.13$ $44/912$ OR The sample space of the experiment is $S = \{1, 2, 3, 4, 5, 6\}$. $P(1) = P(2) = P(3) = P(4) = P(5) = P(6) = 1/6$ <table border="0"> <tr> <td>X</td> <td>1</td> <td>2</td> <td>3</td> <td>4</td> <td>5</td> <td>6</td> </tr> <tr> <td>P(X)</td> <td>1/6</td> <td>1/6</td> <td>1/6</td> <td>1/6</td> <td>1/6</td> <td>1/6</td> </tr> </table> $E(X) = \sum_{i=1}^6 xp = 21/6$ $E(X^2) = 91/6$ $\text{Var}(X) = E(X^2) - (E(X))^2 = 35/12$	X	1	2	3	4	5	6	P(X)	1/6	1/6	1/6	1/6	1/6	1/6	1.5 1.5 0.5 0.5 0.5 0.5 1
X	1	2	3	4	5	6										
P(X)	1/6	1/6	1/6	1/6	1/6	1/6										
28	$\int_0^{\pi/2} \sqrt{\sin \phi} \cdot \cos^4 \phi \cdot \cos \phi d\phi$ $\sin \phi = t, \cos \phi d\phi = dt$ Evaluation of integration $ans = \frac{64}{231}$ OR $\int_0^1 x(1-x)^n dx = \int_0^1 (1-x)(x)^n dx$ applying prop $= \int_0^1 (x)^n - (x)^{n+1} dx$ $= 1/(n+1) - 1/(n+2)$ $= 1/(n+1)(n+2)$	0.5 0.5 1.5 0.5 1 0.5 0.5 1														
29	$dy/dx = (x + 2y)/(x - y)$ $F(x, y) = (x + 2y)/(x - y)$ $F(kx, ky) = (kx + 2ky)/(kx - ky)$ $= k^0(x + 2y)/(x - y)$ $x^2 \frac{dy}{dx} = x^2 - 2y^2 + xy$ $Dy/dx = (x^2 - 2y^2 + xy)/x^2$ Put $y = vx$ Solving de $\frac{1}{2\sqrt{2}} \log \left \frac{x + \sqrt{2}y}{x - \sqrt{2}y} \right = \log x + C$	0.5 2 0.5 0.5 0.5 2														
30	We have $Z = 400x + 300y$ subject to $x + y \leq 200, x \leq 40, x \geq 20, y \geq 0$ The corner points of the feasible region are $C(20, 0), D(40, 0), B(40, 160), A(20, 180)$ 															
	<table border="1"> <thead> <tr> <th>Corner Point</th> <th>Z = 400x + 300y</th> </tr> </thead> <tbody> <tr> <td>C(20, 0)</td> <td>8000</td> </tr> <tr> <td>D(40, 0)</td> <td>16000</td> </tr> </tbody> </table>	Corner Point	Z = 400x + 300y	C(20, 0)	8000	D(40, 0)	16000									
Corner Point	Z = 400x + 300y															
C(20, 0)	8000															
D(40, 0)	16000															

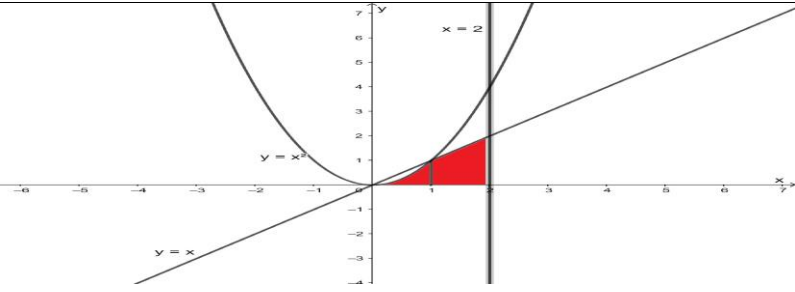
	<table border="1"> <tbody> <tr> <td>B(40,160)</td> <td>64000</td> </tr> <tr> <td>A(20,180)</td> <td>62000</td> </tr> </tbody> </table>	B(40,160)	64000	A(20,180)	62000		
B(40,160)	64000						
A(20,180)	62000						
	Maximum profit occurs at $x= 40, y=160$ and the maximum profit = ₹ 64,000		1 1 1				
31	Put $x^2 = y$ Partial fraction $-\frac{1}{3} \tan^{-1} x + \frac{2}{3} \tan^{-1} \frac{x}{2} + C$		0.5 1.5 0.5				
32	 <p>The points of intersection of the parabola $y = x^2$ and the line $y = x$ are (0, 0) and (1, 1). Required Area = $\int_0^1 y dx + \int_1^2 y dx$ Required Area = $\int x^2 dx + \int x dx$</p>	(Correct fig: 1 Mark)	$\frac{1}{2}$ 2 1+1/2				
33	R is reflexive R is symmetric R is transitive R is equivalence All the triangle		1 1 1 1 1				
34	<p>The position vector of P lying on the line $\vec{r} = 6\hat{i} + 2\hat{j} + 2\hat{k} + \lambda(\hat{i} - 2\hat{j} + 2\hat{k})$ is $(6 + \lambda)\hat{i} + (2 - 2\lambda)\hat{j} + (2 + 2\lambda)\hat{k}$ for some λ The position vector of Q lying on the line $\vec{r} = -4\hat{i} - \hat{k} + \mu(3\hat{i} - 2\hat{j} - 2\hat{k})$ is $(-4 + 3\mu)\hat{i} + (-2\mu)\hat{j} + (-1 - 2\mu)\hat{k}$ for some μ $\vec{PQ} = (-10 + 3\mu - \lambda)\hat{i} + (-2\mu - 2 + 2\lambda)\hat{j} + (-3 - 2\mu - 2\lambda)\hat{k}$ Since, PQ is perpendicular to both the lines $(-10 + 3\mu - \lambda) + (-2\mu - 2 + 2\lambda)(-2) + (-3 - 2\mu - 2\lambda)2 = 0,$ <i>i. e.,</i> $\mu - 3\lambda = 4 \dots(i)$ and $(-10 + 3\mu - \lambda)3 + (-2\mu - 2 + 2\lambda)(-2) + (-3 - 2\mu - 2\lambda)(-2) = 0,$ <i>i. e.,</i> $17\mu - 3\lambda = 20 \dots(ii)$ solving (i) and (ii) for λ and μ, we get $\mu = 1, \lambda = -1$. The position vector of the points, at which they should be so that the distance between them is the shortest, are $5\hat{i} + 4\hat{j}$ and $-\hat{i} - 2\hat{j} - 3\hat{k}$ $\vec{PQ} = -6\hat{i} - 6\hat{j} - 3\hat{k}$ The shortest distance = $\vec{PQ} = \sqrt{6^2 + 6^2 + 3^2} =$</p>		$\frac{1}{2}$ $\frac{1}{2}$ $\frac{1}{2}$ $\frac{1}{2}$ 1 $\frac{1}{2}$ 1				
35	To express system of equation as a product of matrices. To express $AX = B$ $X = A^{-1} B$		1				

	To find A^{-1} Correct solution, $x= 1$, $y=2$, $z= 3$	3 1
36	1. $+1/2, -1/2$ 2. 3588 3. $(-1/2, 0) \cup (1/2, \infty)$ OR $R - (-1/2, 0) \cup (1/2, \infty)$	1 1 2
37	1. c) $2x - 5$ 2. a) yes 3. c) function is not differentiable	1 1 2
38	Let P be the event that the shell fired from A hits the plane and Q be the event that the shell fired from B hits the plane. The following four hypotheses are possible before the trial, with the guns operating independently: $E_1 = PQ, E_2 = \bar{P}\bar{Q}, E_3 = \bar{P}Q, E_4 = P\bar{Q}$ Let E = The shell fired from exactly one of them hits the plane. $P(E_1) = 0.3 \times 0.2 = 0.06, P(E_2) = 0.7 \times 0.8 = 0.56,$ $P(E_3) = 0.7 \times 0.2 = 0.14, P(E_4) = 0.3 \times 0.8 = 0.24$ $P\left(\frac{E}{E_1}\right) = P\left(\frac{E}{E_2}\right) = 0, P\left(\frac{E}{E_3}\right) = P\left(\frac{E}{E_4}\right) = 1$ $P(E) = P(E_1).P\left(\frac{E}{E_1}\right) + P(E_2).P\left(\frac{E}{E_2}\right) + P(E_3).P\left(\frac{E}{E_3}\right) + P(E_4).P\left(\frac{E}{E_4}\right)$ $= 0.14 + 0.24 = 0.38$ By Bayes' Theorem, $P\left(\frac{E_3}{E}\right) = \frac{P(E_3).P\left(\frac{E}{E_3}\right)}{P(E_1).P\left(\frac{E}{E_1}\right) + P(E_2).P\left(\frac{E}{E_2}\right) + P(E_3).P\left(\frac{E}{E_3}\right) + P(E_4).P\left(\frac{E}{E_4}\right)}$ $P\left(\frac{E_3}{E}\right) = \frac{0.14}{0.38}$ $P\left(\frac{E_3}{E}\right) = \frac{7}{19}$	1 1 2

Time 3 Hours

M.M. 80

General Instructions: -

- 1) All questions are compulsory.
- 2) The question paper comprises three sections A,B,C,D and E. This question paper carries 38 questions. Each section is compulsory. There is no overall choice . However internal choice has been provided in some questions . You have to attempt only one of alternatives in all such questions.
- 3) **Section A** has **18 MCQ's and 02 Assertion-Reason** based questions of 1 mark each.
Section B has **5 Very Short Answer (VSA)-type questions of 2 marks each.**
Section C has **6 Short Answer (SA)-type questions of 3 marks each.**
Section D has **4 Long Answer (LA)-type questions of 5 marks each.**
Section E has **3 source based/case based/passage based/integrated units of assessment (4 marks each) with sub parts.**

SECTION-A

(Multiple Choice Questions)

Each question carries 1 mark

1. In the set $A = \{1,2,3\}$, relation $R = \{(1,3)\}$ is
(a) Equivalence (b) Reflexive (c) Symmetric (d) Transitive
2. If $\cos\left(\sin^{-1}\frac{3}{5} + \cos^{-1}x\right) = 0$, then x is equal to
(a) $1/5$ (b) $3/5$ (c) 0 (d) 1
3. If A and B are two matrices of the order $3 \times m$ and $3 \times n$ respectively and $m=n$, then the order of matrix $(5A - 2B)$ is
(a) $m \times 3$ (b) 3×3 (c) $m \times n$ (d) $3 \times n$
4. Let A be a square matrix of order 3×3 . What is the value of $|2A|$, where $|A| = 4$.
(a) 8 (b) 16 (c) 24 (d) 32
5. $f(x) = x^x$ has a stationary point at
(a) $x=e$ (b) $x=1/e$ (c) $x=1$ (d) $x=\sqrt{e}$
6. The rate of change of the area of a circle with respect to its radius r at $r=6$ cm is
(a) 10π (b) 12π (c) 8π (d) 11π
7. $\int_0^{\frac{\pi}{8}} \tan^2(2x) dx$ is equal to
(a) $\frac{4-\pi}{8}$ (b) $\frac{4+\pi}{8}$ (c) $\frac{4-\pi}{4}$ (d) $\frac{4-\pi}{2}$
8. $\int_{-1}^2 |x| dx$ is equal to
(a) 1 (b) $3/2$ (c) 2 (d) $5/2$
9. The area of the region bounded by the curves $x = at^2$ and $y = at$ between the ordinate corresponding to $t = 1$ and $t = 2$ is
(a) $\frac{56}{3} a^2$ (b) $\frac{40}{3} a^2$ (c) 5π (d) none of these
10. The maximum number of equivalence relation on the set $A = \{1,2,3\}$ are

- (a) 1 (b) 2 (c) 3 (d) 5

11. The value of λ for which the vectors $3i - 6j + k$ and $2i - 4j + \lambda k$ are parallel is

- (a) $2/3$ (b) $3/2$ (c) $5/2$ (d) $2/5$

12. The equation of x-axis in space is

- (a) $x=0, y=0$ (b) $x=0, z=0$ (c) $x=0$ (d) $y=0, z=0$

13. The number of vectors of unit length perpendicular to the vector $j + k$ and $2i + j + 2k$ is

- (a) 1 (b) 2 (c) 3 (d) 4

14. If the direction cosines of a line are k, k, k then

- (a) $k > 0$ (b) $0 < k < 1$ (c) $k=1$ (d) $k = \frac{1}{\sqrt{3}}$ or $k = \frac{-1}{\sqrt{3}}$

15. From the set $\{1, 2, 3, 4, 5\}$, two numbers a and b ($a \neq b$) are chosen at random. The probability that a/b is an integer is

- (a) $1/3$ (b) $1/4$ (c) $1/2$ (d) $3/5$

16. The optimal value of the objective function is attained at the points

- (a) Given by intersection of inequation with y-axis only.
(b) Given by intersection of inequation with x-axis only.
(c) Given by corner points of the feasible region .
(d) None of these

17. Three persons A, B and C fire at a target in turn, starting with A. Their probability of hitting the target are 0.4, 0.3 and 0.2 respectively. The probability of two hits is

- (a) 0.25 (b) 0.188 (c) 0.399 (d) 0.475

18. In an LPP, if the objective function $Z = ax + by$ has the same maximum value on two corner points of the feasible region, then the number of points of which Z_{\max} occurs is

- (a) 0 (b) 2 (c) finite (d) infinite

ASSERTION-REASON BASED QUESTIONS

In the following questions, a statement of assertion (A) is followed by a statement of Reason (R). Choose the correct answer out of the following choices.

- (a) Both A and R are true and R is the correct explanation of A.

(b) Both A and R are true but R is not the correct explanation of A.

(c) A is true but R is false.

(d) A is false but R is true.

19. Assertion(A) : If A and B are two independent events and it is given that $P(A)=2/5$, $P(B)= 3/5$, then $P(A\cap B)=6/25$.

Reason(R) : $P(A\cap B)= P(A) \times P(B)$, where A and B are two independent events.

20. Assertion(A) : If A is a square matrix such that $A^2=A$, then $(I+A)^2 - 3A = I$

Reason(R) : $AI=IA=A$

SECTION-B

This section comprises of very short answer type-questions (VSA) of 2 marks each

21. Evaluate : $\int \frac{\sin^6 x + \cos^6 x}{\cos^2 x \sin^2 x} dx$

22. Write $\cot^{-1} \frac{1}{\sqrt{x^2-1}}$, $|x| > 1$ in simplest form.

Or

Prove the following

$$\cos[\tan^{-1}\{\sin(\cot^{-1} x)\}] = \frac{\sqrt{1+x^2}}{\sqrt{2+x^2}}$$

23. If $x = a \cos \theta$; $y = b \sin \theta$, then find $\frac{d^2y}{dx^2}$.

24. A line passes through $(2, -1, 3)$ and is perpendicular to the lines $\vec{r} = \hat{i} + \hat{j} - \hat{k} + \lambda(2\hat{i} - 2\hat{j} + \hat{k})$ and $\vec{r} = 2\hat{i} - \hat{j} - 3\hat{k} + \mu(\hat{i} + 2\hat{j} + 2\hat{k})$. Obtain its equation in vector and Cartesian form .

25. Show that the function f is given by $f(x) = \tan^{-1}(\sin x + \cos x)$ is decreasing for all $x \in \left(\frac{\pi}{4}, \frac{\pi}{2}\right)$.

OR

A ladder 5 m long is leaning against a wall . The bottom of the ladder is pulled along the ground, away from the wall , at the rate of 2 cm/sec . How fast is its height on the wall decreasing when the foot of the ladder is 4 m away from the wall ?

SECTION-C

(This section comprises of short answer type questions (SA) of 3 marks each)

26. Show that the relation S in the set $A = \{x \in Z : 0 \leq x \leq 12\}$ given by $S = \{(a, b) : a, b \in Z, |a - b| \text{ is divisible by } 3\}$ is an equivalence relation .

27. Show that the points $A(a, b+c)$, $B(b, c+a)$, $C(c, a+b)$ are collinear .

OR

If $A = \begin{bmatrix} 2 & 3 \\ 5 & -2 \end{bmatrix}$, write A^{-1} in terms of A .

28. Evaluate : $\int_{\pi/6}^{\pi/3} \frac{dx}{1 + \sqrt{\tan x}}$

Or

Evaluate : $\int \frac{dx}{\sin(x-a)\cos(x-b)}$

29. Solve : $x \frac{dy}{dx} + y - x + xy \cot x = 0$ ($x \neq 0$)

Or

Find the particular solution of the differential equation

$(1 + e^{2x})dy + (1 + y^2)e^x dx = 0$ given that $y = 1$ when $x = 0$

30. Let vector $\vec{a} = \hat{i} + 4\hat{j} + 2\hat{k}$, $\vec{b} = 3\hat{i} - 2\hat{j} + 7\hat{k}$ and $\vec{c} = 2\hat{i} - \hat{j} + 4\hat{k}$. Find a vector \vec{d} which is perpendicular to the plane containing \vec{a} and \vec{b} , and $\vec{c} \cdot \vec{d} = 15$.

Or

Show that two lines $\vec{r} = 2\hat{i} - \hat{k} + \lambda(\hat{i} + \hat{j} - 2\hat{k})$ & $\vec{r} = \hat{i} - \hat{j} + \hat{k} + \mu(-\hat{i} + 2\hat{j} + 2\hat{k})$ intersect also find the point of intersection.

31. Solve the following linear programming problem graphically :

Minimize $Z = 200x + 500y$; subject to constraints

$x + 2y \geq 10$; $3x + 4y \leq 24$; $x \geq 0$; $y \geq 0$

SECTION-D

(This section comprises of long answer-type questions (LA) of 5 marks each)

32. The sum of perimeter of a circle and a square is k , where k is some constant . Prove that the sum of their areas is least when the side of the square is double the radius of the circle.

OR

Find the area of the greatest rectangle that can be inscribed in an ellipse $\frac{x^2}{a^2} + \frac{y^2}{b^2} = 1$.

33. In a family there are five children. Two children are selected at random, if they are found to be girls find the probability that the family has three girls and two boys.

- 34.** Find the area of the region bounded between the parabola $4y = 3x^2$ and the line $3x - 2y + 12 = 0$

OR

If the area bounded by the parabola $y^2 = 16ax$ and the line $y = 4mx$ is $\frac{a^2}{12}$ sq. units, then using integration, find the value of m .

- 35.** Find the shortest distance between the lines whose vector equations are: $\vec{r} = (1 - t)\hat{i} + (t - 2)\hat{j} + (3 - 2t)\hat{k}$ and $\vec{r} = (s + 1)\hat{i} + (2s - 1)\hat{j} - (2s + 1)\hat{k}$

SECTION – E

(This section comprises of with two sub-parts. First two case study questions have three sub of marks 1, 1, 2 respectively. The third case study question has two sub marks each.)

Three schools A, B and C organized a mela for collecting funds for helping the rehabilitation of flood victims. They sold hand made fans, mats and plates from recycled material at a cost of ₹ 25, ₹ 100 and ₹ 50 each. The number of articles sold by school A, B, C are given below.

School \ Article	A	B	C
Fans	40	25	35
Mats	50	40	50
Plates	20	30	40



- 36.** Based on above information, answer the following questions.

- What is the fund collected by school A by selling the given articles ?
- What is the fund collected by school B by selling the given articles ?
- What is the total fund collected for required purpose ?

- 37.**

$P(x) = -5x^2 + 125x + 37500$ is the total profit function of a company, where x is the production of the company.



1. What will be the production when the profit is maximum?
2. What will be the maximum profit?
3. Check in which interval the profit is strictly increasing .

OR

What will be production of the company when the profit is Rs 38250?

- 38.** Polio drops are delivered to 50K children in a district. The rate at which polio drops are given is directly proportional to the number of children who have not been administered the drops. By the end of 2nd week half the children have been given the polio drops. How many will have been given the drops by the end of 3rd week can be estimated using the solution to the differential equation $\frac{dy}{dx} = k(50 - y)$ where x denotes the number of weeks and y the number of children who have been given the drops.
- (i) What is the solution of the differential equation $\frac{dy}{dx} = k(50 - y)$?
 - (ii) What is the value of c in the particular solution given that $y(0)=0$ and $k = 0.049$?

MARKING SCHEME		
1	(d)	1
2	(b)	1
3	(d)	1
4	(d)	1
5	(b)	1
6	(b)	1
7	(a)	1
8	(d)	1
9	(a)	1
10	(d)	1
11	(a)	1
12	(d)	1
13	(b)	1
14	(d)	1
15	(b)	1
16	(c)	1
17	(b)	1
18	(d)	1
19	(a)	1
20	(a)	1
21	<p>Let $I = \int \frac{\sin^6 x + \cos^6 x}{\sin^2 x \cos^2 x} dx$</p> <p>$= \int \frac{(\sin^2 x)^3 + (\cos^2 x)^3}{\sin^2 x \cos^2 x} dx$</p> <p>$= \int \frac{(\sin^2 x + \cos^2 x)(\sin^4 x + \cos^4 x - \sin^2 x \cos^2 x)}{\sin^2 x \cos^2 x} dx$</p> <p>$= \int \frac{(\sin^2 x + \cos^2 x)^2 - 3\sin^2 x \cos^2 x}{\sin^2 x \cos^2 x} dx$</p> <p>$= \int \left(\frac{1}{\sin^2 x \cos^2 x} - 3 \right) dx$</p> <p>$= \int \frac{\sin^2 + \cos^2 x}{\sin^2 x \cos^2 x} dx - 3x + C$</p> <p>$= \int \sec^2 x dx + \int \operatorname{cosec}^2 x dx - 3x + C$</p> <p>$I = \tan x - \cot x - 3x + C$</p>	1 1

22 or

$$\text{LHS} = \cos [\tan^{-1} \{\sin (\cot^{-1} x)\}]$$

Let $x = \cot \theta$

$$\begin{aligned} \text{LHS} &= \cos [\tan^{-1} (\sin \theta)] \\ &= \cos \left[\tan^{-1} \left(\frac{1}{\sqrt{1 + \cot^2 \theta}} \right) \right] = \cos \left[\tan^{-1} \left(\frac{1}{\sqrt{1 + x^2}} \right) \right] \dots(i) \end{aligned}$$

$$\text{Let } \theta_1 = \tan^{-1} \left(\frac{1}{\sqrt{1 + x^2}} \right) \Rightarrow \tan \theta_1 = \frac{1}{\sqrt{1 + x^2}}$$

$$\cos \theta_1 = \frac{\sqrt{1 + x^2}}{\sqrt{2 + x^2}} \Rightarrow \theta_1 = \cos^{-1} \frac{\sqrt{1 + x^2}}{\sqrt{2 + x^2}}$$

Now, put θ_1 in equation (i), we get

$$\cos \left[\cos^{-1} \frac{\sqrt{1 + x^2}}{\sqrt{2 + x^2}} \right] = \frac{\sqrt{1 + x^2}}{\sqrt{2 + x^2}}$$

1

1

23

$x = a \cos \theta, y = b \sin \theta$ at $\theta = \frac{\pi}{4}$

Differentiating x and y w.r.t. θ , we get

$$\frac{dx}{d\theta} = \frac{d}{d\theta} (a \cos \theta)$$

$$= a \frac{d}{d\theta} (\cos \theta)$$

$$= a (-\sin \theta)$$

$$= -a \sin \theta \dots\dots\dots(1)$$

and

$$\frac{dy}{d\theta} = \frac{d}{d\theta} (b \sin \theta)$$

$$= b \frac{d}{d\theta} (\sin \theta)$$

$$= b \cos \theta$$

$$\therefore \frac{dy}{dx} = \frac{\frac{dy}{d\theta}}{\frac{dx}{d\theta}}$$

$$= \frac{b \cos \theta}{-a \sin \theta}$$

$$= \left(-\frac{b}{a}\right) \cot \theta$$

and

$$\frac{d^2y}{dx^2} = \frac{d}{dx} \left[\left(-\frac{b}{a}\right) \cot \theta \right]$$

$$= -\frac{b}{a} \cdot (\cot \theta) \times \frac{d\theta}{dx}$$

$$= \left(-\frac{b}{a}\right) (-\operatorname{cosec}^2 \theta) \times \frac{1}{\frac{dx}{d\theta}}$$

$$= \left(\frac{b}{a}\right) \operatorname{cosec}^2 \theta \times \frac{1}{-a \sin \theta} \dots\dots\dots[\text{By(1)}]$$

$$= \left(-\frac{b}{a^2}\right) \operatorname{cosec}^3 \theta$$

$$\therefore \left(\frac{d^2y}{dx^2}\right) \text{ at } \theta = \frac{\pi}{4}$$

$$= \left(-\frac{b}{a^2}\right) \operatorname{cosec}^3 \frac{\pi}{4}$$

$$= \frac{-b}{a^2} \times (\sqrt{2})^3$$

$$= -\frac{2\sqrt{2}b}{a^2}$$

1

1

24	$(2\hat{i} - 2\hat{j} + \hat{k}) \times (\hat{i} + 2\hat{j} + 2\hat{k}) = \begin{vmatrix} \hat{i} & \hat{j} & \hat{k} \\ 2 & -2 & 1 \\ 1 & 2 & 2 \end{vmatrix} = -6\hat{i} - 3\hat{j} + 6\hat{k} \text{ or, } \vec{b} = 2\hat{i} + \hat{j} - 2\hat{k}$ <p>Position vector of given point (2, -1, 3) is. $\vec{a} = 2\hat{i} - \hat{j} + 3\hat{k}$</p> <p>Using</p> $\vec{r} = \vec{a} + \lambda\vec{b}, \text{ the required vector equation of line is : } \vec{r} = 2\hat{i} - \hat{j} + 3\hat{k} + \lambda(2\hat{i} + \hat{j} - 2\hat{k})$ <p>And, Cartesian form of the line is : $\frac{x-2}{2} = \frac{y+1}{1} = \frac{z-3}{-2}$</p>	1 1
25	$\frac{dy}{dt} = \frac{-x}{\sqrt{25-x^2}} \cdot \frac{dx}{dt}$ <p>It is given that $\frac{dx}{dt} = 2\text{cm/s}$</p> $\therefore \frac{dy}{dt} = \frac{-2x}{\sqrt{25-x^2}}$ <p>Now, when $x = 4\text{m}$, we have:</p> $\frac{dy}{dt} = \frac{-2 \times 4}{\sqrt{25-4^2}} = -\frac{8}{3}$ <p>Hence, the height of the ladder on the wall is decreasing at the rate of $\frac{8}{3}$ cm/s.</p> <p>OR</p>	1 1 1 1
Section-C		
26		
27	$[x_1(y_2 - y_3) + x_2(y_3 - y_1) + x_3(y_1 - y_2)] = 0$ $[a(c + a - a - b) + b(a + b - b - c) + c(b + c - c - a)] = 0$ $[ac - ab + ab - bc + bc - ac] = 0$ $= 0$ <p>The points $A(a, b+c)$, $B(b, c+a)$, $C(c, a+b)$ are collinear.</p> <p>OR</p> $\mathbf{A}^{-1} = \frac{1}{\mathbf{A}} \text{adj } \mathbf{A}$ $= \frac{1}{-19} \begin{bmatrix} -2 & -3 \\ -5 & 2 \end{bmatrix}$ $= \frac{1}{19} \begin{bmatrix} 2 & 3 \\ 5 & -2 \end{bmatrix}$ $= \frac{1}{19} \mathbf{A}$	1 1 1 1 1

28	$2I = \int_{\frac{\pi}{6}}^{\frac{\pi}{3}} \frac{\sqrt{\cos x} + \sqrt{\sin x}}{\sqrt{\cos x} + \sqrt{\sin x}} dx$ $2I = \int_{\frac{\pi}{6}}^{\frac{\pi}{3}} 1. dx$ $2I = [x]_{\frac{\pi}{6}}^{\frac{\pi}{3}}$ $I = \frac{1}{2} \left[\frac{\pi}{3} - \frac{\pi}{6} \right]$ $I = \frac{1}{2} \left[\frac{2\pi - \pi}{6} \right]$ $I = \frac{\pi}{12}$ <p>OR</p> $= \frac{1}{\cos(b-a)} \int \left[\frac{\cos(x-a)\cos(x-b)}{\sin(x-a)\cos(x-b)} dx \right.$ $\left. + \frac{\sin(x-a)\sin(x-b)}{\sin(x-a)\cos(x-b)} dx \right]$ $= (1/\cos(b-a)) \int (\cot(x-a) + \tan(x-b)) dx$ $= (1/\cos(b-a)) [\log \sin(x-a) - \log (\sec(x-b))] + c$ $= (1/\cos(b-a)) [\log \sin(x-a)\cos(x-b)] + c$	1 1 1 1 1 1
29	$\tan^{-1} y + \tan^{-1}(e^x) = \frac{\pi}{2}$ $y(x \sin x) = \int x \cdot \sin x dx$ $= -x \cdot \cos x + \int \cos x dx$ <p>Or</p> $\tan^{-1} y = -\tan^{-1}(e^x) + C$	1 1 1 1.5 1.5
30	<p>1. \vec{d} is parallel to $\vec{a} \times \vec{b} \Rightarrow \lambda(\vec{a} \times \vec{b})$</p> $\therefore \vec{d} = 32\lambda\hat{i} - \lambda\hat{j} - 14\lambda\hat{k}$ <p>Using $\vec{c} \cdot \vec{d} = 15, \lambda = 5/3$</p>	1 1

	<p style="text-align: center;">$\therefore \vec{d} = \frac{5}{3} (32\hat{i} - \hat{j} - 14\hat{k})$</p> <p>Or</p> $\vec{r} = 2\hat{i} - \hat{k} + \lambda(\hat{i} + \hat{j} - 2\hat{k})$ $\vec{r} = \hat{i} - \hat{j} + \hat{k} + \mu(-\hat{i} + 2\hat{j} + 2\hat{k})$ $\therefore 2 + \lambda = 1 - \mu \quad (i)$ $\lambda = -1 + \mu \quad (ii)$ $-1 - 2\lambda = 1 + 2\mu \quad (iii)$ <p>Solving (i) and (ii) $\lambda = -1$ & $\mu = 0$ which satisfy (iii) \therefore they intersect point (1, -1, 1)</p>	<p>1</p> <p>1</p> <p>1</p> <p>1</p>
31	<p>Corner points (0,5), (4,3) ; (0,6) ;</p> <p>2300 at (4,3)</p>	<p>2</p> <p>1</p>
32	$2\pi r + 4s = k$ $s = \frac{1}{4}(k - 2\pi r)$ $\frac{dA_T}{dr} = \frac{d}{dr} \left(\pi r^2 + \frac{1}{16}(k - 2\pi r)^2 \right)$ $0 = 2\pi r + \frac{1}{16} 2(k - 2\pi r) \times (-2\pi)$ $0 = 2\pi r - \pi(s)$ $s = 2r$	<p>1</p> <p>1</p> <p>1</p> <p>1</p> <p>1</p>

	<p>or</p> <p>The area A of the rectangle is $4xy$ i.e. $A = 4xy$ which gives $A^2 = 16x^2y^2 = s$ (say)</p> <p>Therefore, $s = 16x^2 \left(1 - \frac{x^2}{a^2}\right) \cdot b^2 = \frac{16b^2}{a^2} (a^2x^2 - x^4)$</p> <p>$\Rightarrow \frac{ds}{dx} = \frac{16b^2}{a^2} \cdot [2a^2x - 4x^3]$.</p> <p>Again, $\frac{ds}{dx} = 0 \Rightarrow x = \frac{a}{\sqrt{2}}$ and $y = \frac{b}{\sqrt{2}}$</p> <p>Now, $\frac{d^2s}{dx^2} = \frac{16b^2}{a^2} [2a^2 - 12x^2]$</p> <p>At $x = \frac{a}{\sqrt{2}}$, $\frac{d^2s}{dx^2} = \frac{16b^2}{a^2} [2a^2 - 6a^2] = \frac{16b^2}{a^2} (-4a^2) < 0$</p> <p>Thus at $x = \frac{a}{\sqrt{2}}$, $y = \frac{b}{\sqrt{2}}$, s is maximum and hence the area A is maximum.</p> <p>Maximum area = $4 \cdot x \cdot y = 4 \cdot \frac{a}{\sqrt{2}} \cdot \frac{b}{\sqrt{2}} = 2ab$ sq units.</p>	<p>1</p> <p>1</p> <p>1</p> <p>1</p> <p>1</p>
33	<p>E: The family has 2 girls & 3 boys.</p> <p>F: The family has 3 girls & 2 boys.</p> <p>G: The family has 4 girls & 1 boy.</p> <p>H: The family has 5 girls</p> <p>A: Two selected children are girls</p> <p>$P(E) = P(F) = P(G) = P(H) = 1/4$</p> <p>$P(A/E) = \frac{C(2,2)}{C(5,2)}$, $P(A/F) = \frac{C(3,2)}{C(5,2)}$, $P(A/G) = \frac{C(4,2)}{C(5,2)}$ & $P(A/H) = \frac{C(5,2)}{C(5,2)}$</p> <p>$P(E/A) = \frac{P(E) \cdot P(A/E)}{\sum P(E) \cdot P(A/E)}$</p> <p>$= \frac{1}{10}$</p>	<p>1</p> <p>1</p> <p>1</p> <p>1</p> <p>1</p>
34	FIGURE	1

Given the equation of parabola $4y = 3x^2 \Rightarrow y = \frac{3x^2}{4} \dots (i)$

and the line $3x - 2y + 12 = 0$

$$\Rightarrow \frac{3x + 12}{2} = y \dots (ii)$$

The line intersect the parabola at $(-2, 3)$ and $(4, 12)$.

Hence the required area will be the shaded region.

$$\begin{aligned} \text{Required Area} &= \int_{-2}^4 \frac{3x + 12}{2} dx - \int_{-2}^4 \frac{3x^2}{4} dx \\ &= \left[\frac{3}{4}x^2 + 6x - \frac{x^3}{4} \right]_{-2}^4 \\ &= (12 + 24 - 16) - (3 - 12 + 2) \end{aligned}$$

$$= 20 + 7 = 27 \text{ square units.}$$

OR

now, area bounded by the curves = $\int_0^{a/m^2} \sqrt{16ax} - 4mx dx$

$$= \sqrt{16a} \int_0^{a/m^2} \sqrt{x} dx - \int_0^{a/m^2} 4mx dx$$

$$a^2/12 = 2a^2/3m^3$$

$$m=2$$

1

1

1

1

1.5

1.5

1

1

35	$\vec{b}_1 \times \vec{b}_2 = \begin{vmatrix} \hat{i} & \hat{j} & \hat{k} \\ -1 & 1 & -2 \\ 1 & 2 & -2 \end{vmatrix} = (-2+4)\hat{i} - (2+2)\hat{j} + (-2-1)\hat{k} = 2\hat{i} - 4\hat{j} - 3\hat{k}$ $\Rightarrow \vec{b}_1 \times \vec{b}_2 = \sqrt{(2)^2 + (-4)^2 + (-3)^2} = \sqrt{4+16+9} = \sqrt{29}$ $\therefore (\vec{b}_1 \times \vec{b}_2) \cdot (\vec{a}_2 - \vec{a}_1) = (2\hat{i} - 4\hat{j} - 3\hat{k}) \cdot (\hat{j} - 4\hat{k}) = -4 + 12 = 8$ <p>Substituting all the values in equation (3), we obtain</p> $d = \left \frac{8}{\sqrt{29}} \right = \frac{8}{\sqrt{29}}$	2.5 1 1 .5
36	(i) 7000/- (ii) 6125/- (iii) 21000/-	1 1 2
37	(i) 12.5 (ii) 38281025/- (iii) (0, 12.5) or 15	1 1 2
38	(i) $-\log 50 - y = kx + c$ (iii) (ii) $\log \frac{1}{50}$	2 2

Kendriya Vidyalaya Sangathan (Raipur-Region)

Sample paper-4 (2022– 23)

Subject: - Mathematics Class-XII

Time: 3 Hours

Maximum Marks: 80.

General Instructions:

- (i) All questions are compulsory.
- (ii) The question Paper consists of Five sections A, B, C, D and E.
- (iii) Section A consists of 18 MCQ questions , and 2 question based on Assertion -Reasoning. One mark each.
- (iv) **Section B** comprises of 5 (VSA) questions of **2 marks** each,
- (v) **Section C** comprises of 6 (SA) questions of **3 marks** each.
- (vi) **Section D** comprises of 4 (LA) questions of **5 marks** each.
- (vii) **Section E** has 3 case study based questions with sub parts **4 marks** each.
- (viii) There is no overall choice. However, internal choice has been provided in 2 questions in section B , 3 question in section C, 2 question in section D. You have to attempt only one of the alternatives in all such questions.
- (ix) Use of calculators is not permitted. You may ask for logarithmic table if required.
- (x) If you wish to re-answer any question, for any reason, please cancel the question already answered.
- (xi) Please write the serial number of question before attempting it.
“15 minutes extra time has been allotted to read this question paper”

Section A [1 mark each]

From Q.1—Q.-20 are multiple choice type questions. Select the correct option.

1. If A is a square matrix of order 3 and $|3A| = K|A|$, then the value of K is
(a) 9 (b) 18 (c) 81 (d) 27
2. If $A = \begin{bmatrix} 1 & 2 \\ 4 & 2 \end{bmatrix}$, then find the value of $|2A|$ is (a) 24 (b) -24 (c) 12 (d) -12.
3. The value of $\hat{i} \cdot (\hat{j} \times \hat{k}) + \hat{j} \cdot (\hat{k} \times \hat{i}) + \hat{k} \cdot (\hat{i} \times \hat{j})$ is
(a) 1 (b) 2 (c) 3 (d) 0
4. If $f(x) = \begin{cases} \frac{\sin 2x}{x}, & x \neq 0 \\ k, & x = 0 \end{cases}$ is continuous at $x = 0$ the value of k is
(a) 1 (b) 2 (c) 3 (d) 0
5. If $y = \sqrt{\sin x + y}$, then $\frac{dy}{dx}$ is equal to
(a) $\frac{\cos x}{2y-1}$ (b) $\frac{\cos x}{1-2y}$ (c) $\frac{\sin x}{1-2y}$ (d) $\frac{\sin x}{2y-1}$
6. Find the sum of the degree and the order for the following differential equation :
 $\frac{d}{dx} \left[\left(\frac{d^2y}{dx^2} \right)^4 \right] = 0$
(a) 1 (b) 2 (c) 3 (d)

7. The corner points of the feasible region determined by the following system of linear inequalities $2x + y \leq 10, x + 3y \leq 15, x \geq 0, y \geq 0$ are $(0,0), (5,0), (3,4)$ and $(0,5)$. Let $Z = px + qy$, where $p, q > 0$. Condition on p and q so that the maximum of Z occurs at both $(3,4)$ and $(0,5)$ is
 (a) $p = q$ (b) $p = 2q$ (c) $p = 3q$ (d) $q = 3p$
8. If θ is the angle between the vectors \vec{a} and \vec{b} , such that $|\vec{a} \times \vec{b}| = |\vec{a} \cdot \vec{b}|$, then θ is
 (a) 0° (b) 45° (c) 120° (d) 180°
9. The value of $\int_0^1 e^{2 \log x} dx$ is
 (a) 0 (b) $\frac{1}{2}$ (c) $\frac{1}{3}$ (d) $\frac{1}{4}$
10. A 3×3 matrix $A = [a_{ij}]$ whose elements are given by $a_{ij} = (i + j)^2$ is
 (a) $\begin{bmatrix} 4 & 9 & 16 \\ 9 & 16 & 25 \\ 16 & 25 & 36 \end{bmatrix}$ (b) $\begin{bmatrix} 4 & 9 & 16 \\ 9 & 16 & 25 \\ 6 & 25 & 126 \end{bmatrix}$ (c) $\begin{bmatrix} 4 & 9 & 16 \\ 9 & 16 & 25 \\ 16 & 25 & 36 \end{bmatrix}$ (d) None of these
11. If the feasible region for a LPP is, then the optimal value of the objective function $z = ax + by$ may or may not exist (a) Bounded (b) Unbounded (c) Both (d) None of these
12. If $A = \begin{bmatrix} \cos \alpha & -\sin \alpha \\ \sin \alpha & \cos \alpha \end{bmatrix}$, then for what value of α , A an identity matrix ?
 (a) 30° (b) 0° (c) 90° (d) None of these.
13. If A is a square matrix of order 3, with $|A| = 9$, then write the value of $|2 \cdot (\text{adj } A)|$
 (a) 620 (b) 648 (c) 720 (d) 748
14. It is given that the event A and B are such that $P(A) = \frac{1}{4}, P(A/B) = \frac{1}{2}$ and $P(B/A) = \frac{2}{3}$, then $P(B)$ is
 (a) $\frac{1}{2}$ (b) $\frac{1}{6}$ (c) $\frac{1}{3}$ (d) $\frac{2}{3}$
15. Find the integrating factor of the following differential equation : $x \log x \frac{dy}{dx} + y = 2 \log x$
 (a) $\log x$ (b) 2 (c) $\log 2$ (d) $\log 3$
16. If $f(x) = \sqrt{\tan \sqrt{x}}$, then find $f'(\frac{\pi^2}{16})$.
 (a) $\frac{\pi}{2}$ (b) $\frac{2}{\pi}$ (c) $\frac{1}{3}$ (d) $\frac{2}{3}$
17. If $|\vec{a}| = 3$, then value of $|-4\vec{a}|$ is
 (a) 4 (b) -12 (c) 12 (d) $\sqrt{12}$
18. The Cartesian equations of a line are $6x - 2 = 3y + 1 = 2z + 2$. The d-ratios of the line are
 (a) 1, 2, 3 (b) 2, 3, 1 (c) 3, 2, 1 (d) none of these

ASSERTION- REASON BASED QUESTIONS

In the following question, a statement of Assertions (A) is followed by a statement of Reason(R)
 Choose the correct answer out of the following choices.

- (a) Both A and R true and R is the correct explanation of A.
 (b) Both A and R true and R is not the correct explanation of A.
 (c) A is true but R is false
 (d) A is false but R is true.
19. **Assertion (A):** The principal value of $\tan^{-1} \left(\tan \frac{7\pi}{6} \right) = \frac{\pi}{6}$.
Reason (R) : $f(x) = \tan^{-1} x, x \in \left(-\frac{\pi}{2}, \frac{\pi}{2} \right)$
20. **Assertion (A):** The acute angle between the lines: $\vec{r} = (2\hat{i} - 5\hat{j} + \hat{k}) + \lambda(3\hat{i} + 2\hat{j} + 6\hat{k})$ and $\vec{r} = (7\hat{i} - 6\hat{k}) + \mu(\hat{i} + 2\hat{j} + 2\hat{k})$ is $\theta = \cos^{-1} \left(\frac{19}{21} \right)$
Reason (R) : The acute angle θ between the lines is given by $\cos \theta = \left| \frac{\vec{b}_1 \cdot \vec{b}_2}{|\vec{b}_1| \cdot |\vec{b}_2|} \right|$

Section B [2 marks each]

21. Write the principal value of :- $4\tan^{-1}(1) + \cos^{-1}\left(-\frac{1}{2}\right)$ **Ans:** $\frac{5\pi}{3}$
 (OR)

Evaluate: $\sin\left[\frac{\pi}{6} - \sin^{-1}\left(-\frac{\sqrt{3}}{2}\right)\right]$ **Ans: 1**

22. The length x of a rectangle is decreasing at the rate of 5 cm / minute and the width y is increasing at the rate of 4 cm / minute, when $x = 8$ cm and $y = 6$ cm, find the rate of change of the area of rectangle.
Ans: 2cm²/min

23. If $\vec{a} = 4\hat{i} + 3\hat{j} + 2\hat{k}$ and $\vec{b} = 3\hat{i} + 2\hat{k}$, find $|\vec{b} \times 2\vec{a}|$ **Ans: 22**
 (OR)

If $|\vec{a}| = 4$, $|\vec{b}| = 3$ and $\vec{a} \cdot \vec{b} = 6\sqrt{3}$, then find $|\vec{a} \times \vec{b}|$ **Ans: $|\vec{a} \times \vec{b}| = 6$**

24. If $y = (\tan^{-1}x)^2$, show that $(x^2 + 1)^2 \cdot \frac{d^2y}{dx^2} + 2x(x^2 + 1) \frac{dy}{dx} = 2$

25. Find a vector \vec{a} of magnitude $5\sqrt{2}$, making an angle of $\frac{\pi}{4}$ with x -axis, $\frac{\pi}{2}$ with y -axis and an acute angle θ with z -axis.
Ans: $\vec{a} = 5\hat{i} + 5\hat{k}$

Section C [3marks each]

26. Find : $\int \frac{dx}{\sqrt{5-4x-2x^2}}$ **Ans: $\frac{1}{2} \sin^{-1} \sqrt{\frac{2}{7}}(x+1) + c$**

27. A card is drawn from a well shuffled deck of 52 cards. The outcome is noted, the card is replaced and the deck reshuffled. Another card is drawn from the deck. What is the probability that the first card is an ace and the second card is a red queen.
Ans: $\frac{1}{338}$
 (OR)

A and B throw a pair of dice alternatively. A wins the game if he gets a total 7 and B wins the game if he gets a total 10. Write their favorable cases. **Ans: A, total 6; B total 3 favorable cases.**

28. Evaluate : $\int \frac{2+\sin 2x}{1+\cos 2x} e^x dx$ **Ans: $e^x \tan x + c$**
 (OR)

Evaluate: $\int_0^\pi \frac{x \sin x}{1+\cos^2 x} dx$ **Ans: $\frac{\pi^2}{4}$**

29. Solve the differential equation : $x \frac{dy}{dx} = y - x \tan\left(\frac{y}{x}\right)$ **Ans: $x \sin \frac{y}{x} = c$**
 (OR)

Find the particular solution of differential equation $\frac{dy}{dx} + y \cot x = 2x + x^2 \cot x$, given that $y = 0$ when $x = \frac{\pi}{2}$
Ans: $y \sin x - x^2 \sin x + \frac{\pi^2}{4} = 0$

30. Solve the following linear programming problem (L. P. P.) graphically:
 Maximize $Z = \frac{15}{2}x + 5y$ Subject to the constraints: $2x + y \leq 60$, $2x + 3y \leq 120$, $x \leq 20$, $x \geq 0$, $y \geq 0$
Ans: 262.50 at (15, 30)

31. Find : $\int \frac{x^3-1}{x^3+x} dx$ **Ans: $x - \log|x| - \tan^{-1}x + \frac{1}{2} \log(x^2 + 1) + c$**

Section D [5 marks each]

32. Find the area of the region bounded by the curve $y^2 = 4x$, y -axis, and the line $y = 3$ **Ans: $\frac{9}{4}$ sq units**

33. Let N denote the set of all natural numbers and R be the relation on $N \times N$ defined by $(a, b) R (c, d)$ iff $ad(b+c) = bc(a+d)$. Show that R is an equivalence relation.
 (OR)

Consider a function $f : \mathbb{R}_+ \rightarrow [-9, \infty)$ given by $f(x) = 5x^2 + 6x - 9$, prove that f is bijective.

34. Find the shortest distance between the following pair of lines :

$$\frac{x-6}{1} = \frac{y-2}{-2} = \frac{z-2}{2}; \quad \frac{x+4}{3} = \frac{y}{-2} = \frac{z+1}{-2}.$$

Ans: 9

(OR)

Find the vector equation of the line passing through the point(1, 2, -4) and is perpendicular to the two

lines $\frac{x-8}{3} = \frac{y+19}{-16} = \frac{z-10}{7}$ and $\frac{x-15}{3} = \frac{y-29}{8} = \frac{z-5}{-5}$ Ans: $\vec{r} = (\hat{i} + 2\hat{j} - 4\hat{k}) + \lambda(2\hat{i} + 3\hat{j} + 6\hat{k})$

35. Find the product AB, where $A = \begin{bmatrix} 1 & -1 & 0 \\ 2 & 3 & 4 \\ 0 & 1 & 2 \end{bmatrix}$, $B = \begin{bmatrix} 2 & 2 & -4 \\ -4 & 2 & -4 \\ 2 & -1 & 5 \end{bmatrix}$ and use it to solve the equations: $x - y = 3, 2x + 3y + 4z = 17, y + 2z = 7$ Ans: $x = 2, y = -1, z = 4$

Section E[4 marks each]

36. An architect designs a building for a multi-national company. The floor consists of a rectangular region with semicircular ends having a perimeter of 200 m as shown below

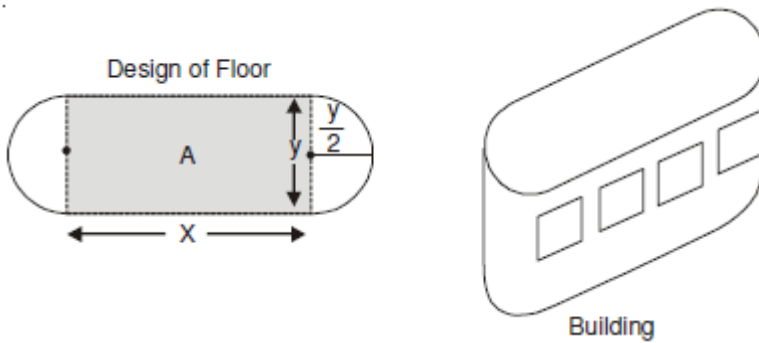

Based on the above information answer the following:

(i) If x and y represents the length and breadth of the rectangular region, then the relation between the variables is

(Ans:) $2x + \pi y = 200$

(ii) The area of the rectangular region A expressed as a function of x is

Ans: $\frac{2}{\pi}(100 - x^2)$

(iii) The maximum value of area A is

Ans $\frac{5000}{\pi} m^2$

OR

(iii) The CEO of the multi-national company is interested in maximizing the area of the whole floor including the semi-circular ends. For this to happen the value of x should be

Ans: 0 m

37. In a park, an open tank is to be constructed using metal sheet with a square base and vertical sides so that it contains 500 cubic meter of water.

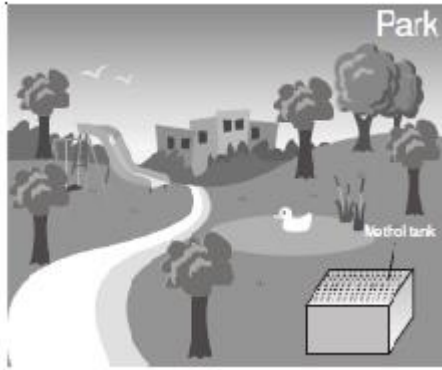

Based on the above information answer the following questions:

- (i) If the edge of square is x meter and height of tank is y m then correct relation is

Ans $x^2y = 500$

- (ii) Relation for surface area of tank in terms of x and y is

Ans $x^2 + 4xy$

- (iii) The surface area of tank is minimum when x is equal to

Ans 10 m

OR

- (iii) The minimum surface area of tank is

Ans 300 sq. m

38. Three persons A, B and C apply for a job in private school for the post of principal. The chances of their selection are in the ratio 2 : 3 : 4 respectively. Management committee given the agenda to improve the sports education, it is estimated that the change may occur with probability 0.8, 0.5 and 0.3 respectively.



On the bases of above situation answer the followings:

- (i) Probability of 'C' that change not take place is

Ans $\frac{7}{10}$

- (ii) Probability of 'A' that change occur is

Ans $\frac{8}{10}$